

OWNERS OPERATING & MAINTENANCE MANUAL

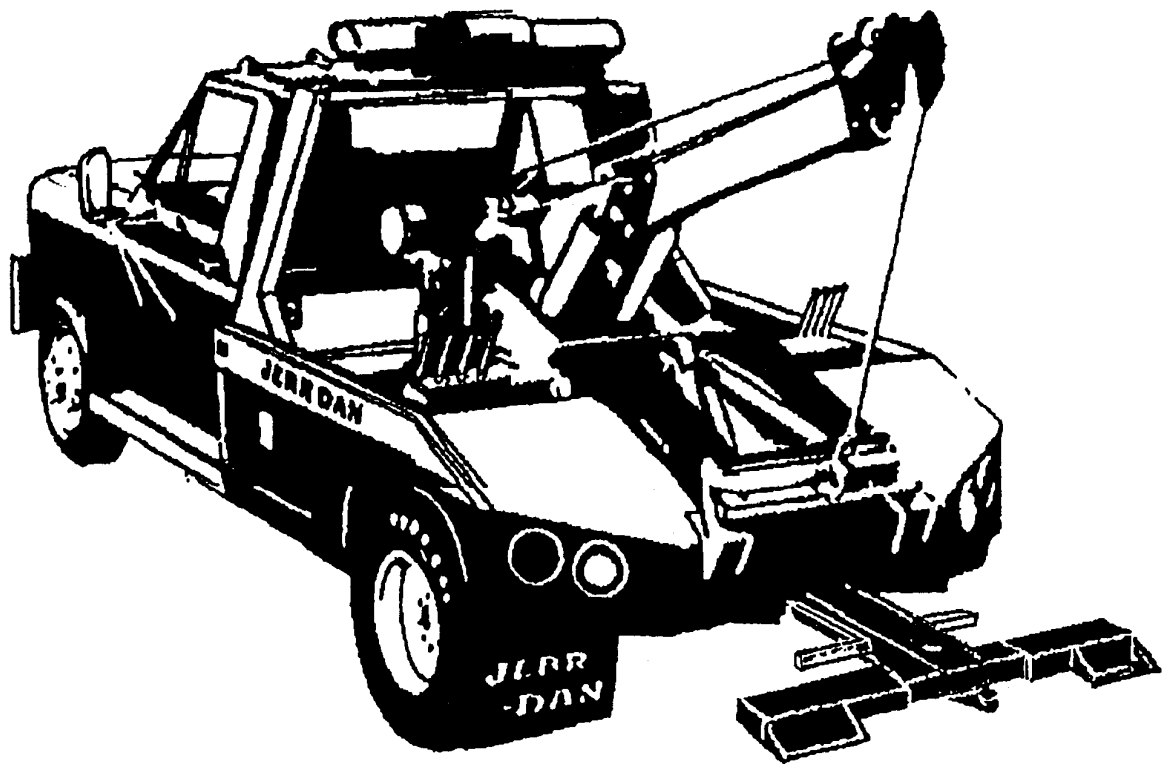

PARTS LIST — BODY ASSEMBLY

Ref. No.	Part No.	Description	Qty.
1	7-114-141223	Capscrew, Flat Head Hex Socket	20
2	A7-590-000009	Lamp Red Clearance w/Mounting Gromment	2
3	B4-178-000016	Clearance Lamp Bracket L.H.	1
4	7-950-140161	Flatwasher	38
5	7-660-142600	Locknut, Nylok	38
6	7-950-160161	Flatwasher	36
7	7-950-160000	Lockwasher	30
8	7-115-161050	Hex Head Bolt	24
9	A7-590-000004	Lamp, Side Marker "Red"	2
10	7-660-162601	Locknut	6
11	7-790-060676	Screw, Self-Tapping	6
12	D4-415-000002	Fender, L.H.	1
13	D3-510-300033	Deck	1
14	7-950-100003	Lockwasher	16
15	D3-899-000003	Toolbox (Chevrolet & G.M.C.)	1
16	D3-899-000002	Toolbox (Ford)	1
17	7-114-100410	Screw, Round Head	16
18	A7-590-000001	Work Lamp	2
19	7-660-152600	Locknut, Nylok	4
20	7-950-150161	Flatwasher	4
21	B7-330-000041	Lubrication Decal (Wheel Lift System)	1
	B7-330-000042	Lubrication Decal (Deck Mounted Winch)	1
	B7-330-000043	Lubrication Decal (Wrecker Boom)	1
22	B7-330-000040	Lubrication Decal (Wheel Lift System)	1
23	D3-455-000001	Door and Frame Assembly	2
24	A4-706-000030	Plate Back-Up	2
25	7-002-000011	Folding Step	2
26	7-111-151013	Screw, Truss Head Machine	4
27	D3-686-000001	Body Panel L.H. (Ford) (60" C.A.)	1
	D3-686-000010	Body Panel L.H. (84" C.A.)	
	D3-686-000003	Body Panel L.H. (Chevrolet & G.M.C.) (60" C.A.)	1
28	A7-590-000005	Lamp, Side Marker "Amber"	2
29	A7-590-000002	Stop, Tail, Turn Lamp w/Mounting Grommet	2
30	7-111-140613	Screw, Truss Head	2
31	7-950-140000	Lockwasher	2
32	7-291-000003	Connector, Trailer	1
33	A7-759-000001	Pop Rivet	32
34	A7-189-000007	Rubber Bumper	4
35	7-114-140823	Capscrew, Flat Head Hex Socket	14
36	B4-178-000015	Light Bracket	2
37	A7-590-000003	Back-Up Lamp w/Mounting Grommet	2

Rev. _____

Date _____

38	B4-754-000001	Tail Light Trim Ring	4
39	A7-590-000008	Work Light	2
40	D3-510-300045	Rear Tail Weldment L.H.	1
41	A7-590-000011	Work Lamp	2
42	D3-510-300046	Rear Tail Weldment R.H.	1
43	7-111-140850	Hex Head Bolt	4
44	B4-178-000017	Clearance Lamp Bracket	1
45	D4-415-000001	Fender R.H.	1
46	7-790-141056	Screw, Self-Tapping	2
47	A7-590-000007	Light Bar	1
48	3-555-581008	Stop Light	2
49	D3-510-150070	Cab Protector	1
50	7-115-160850	Hex Head Bolt	6
51	D3-686-000002	Body Panel R.H. (60" C.A.)	1
	D3-686-000011	Body Panel R.H. (84" C.A.)	
52	D3-899-000001	Tool Box R.H.	1

BODY ASSEMBLY

**IDENTIFICATION
PLATE**

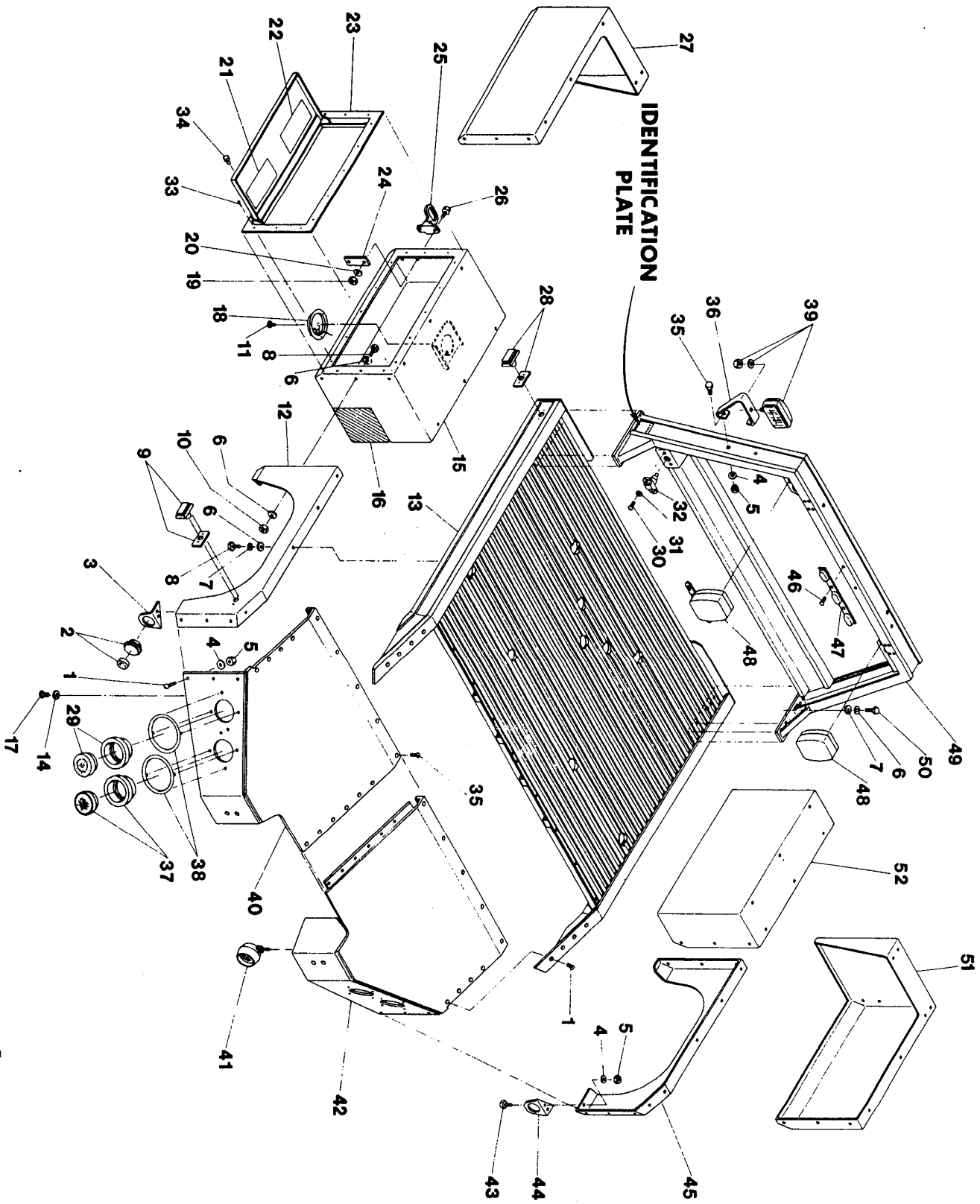

PARTS LIST — TUNNEL TOOL BOX

Ref. No.	Part No.	Description	Qty.
1	C4-017-000189	Angle R.H.	1
2	7-950-140161	Flatwasher	10
3	7-660-142600	Locknut ("Nylok")	10
4	7-660-182301	Locknut ("Flanged")	4
5	7-950-180161	Flatwasher	4
6	7-115-181450	Hex Head Capscrew	4
7	C4-017-000188	Angle, L.H.	1
8	A7-590-000001	Tool Box Light	2
9	D3-455-000003	Door and Frame Assembly	2
10	A7-759-000001	Rivet	32
11	7-115-161050	Hex Head Bolt	10
12	D3-899-000004	Tool Box Weldment	1
13	3-555-581008	Stop Light	2
14	7-790-141050	Screw, Self Tapping	2
15	A7-590-000007	Light Bar	1
16	7-114-140823	Capscrew Flat Head Hex Socket	4
17	7-291-000003	Trailer Connector	2
18	7-950-140000	Lockwasher	2
19	B4-178-000015	Light Bracket	2
20	A7-590-000008	Work Light	2
21	7-790-060676	Self Tapping Screw	6
22	A7-189-000007	Bumper, Rubber	4
23	7-660-140000	Nut, Hex	2
24	7-111-140613	Screw, Truss Head Machine	2
25	D3-241-000006	Cab Protector	1
26	7-115-161050	Hex Cap Screw	4
27	7-950-160161	Flatwasher	4
28	7-114-140818	Hex Socket Button Head Cap Screw	6

Rev. _____

Date _____

TUNNEL TOOL BOX

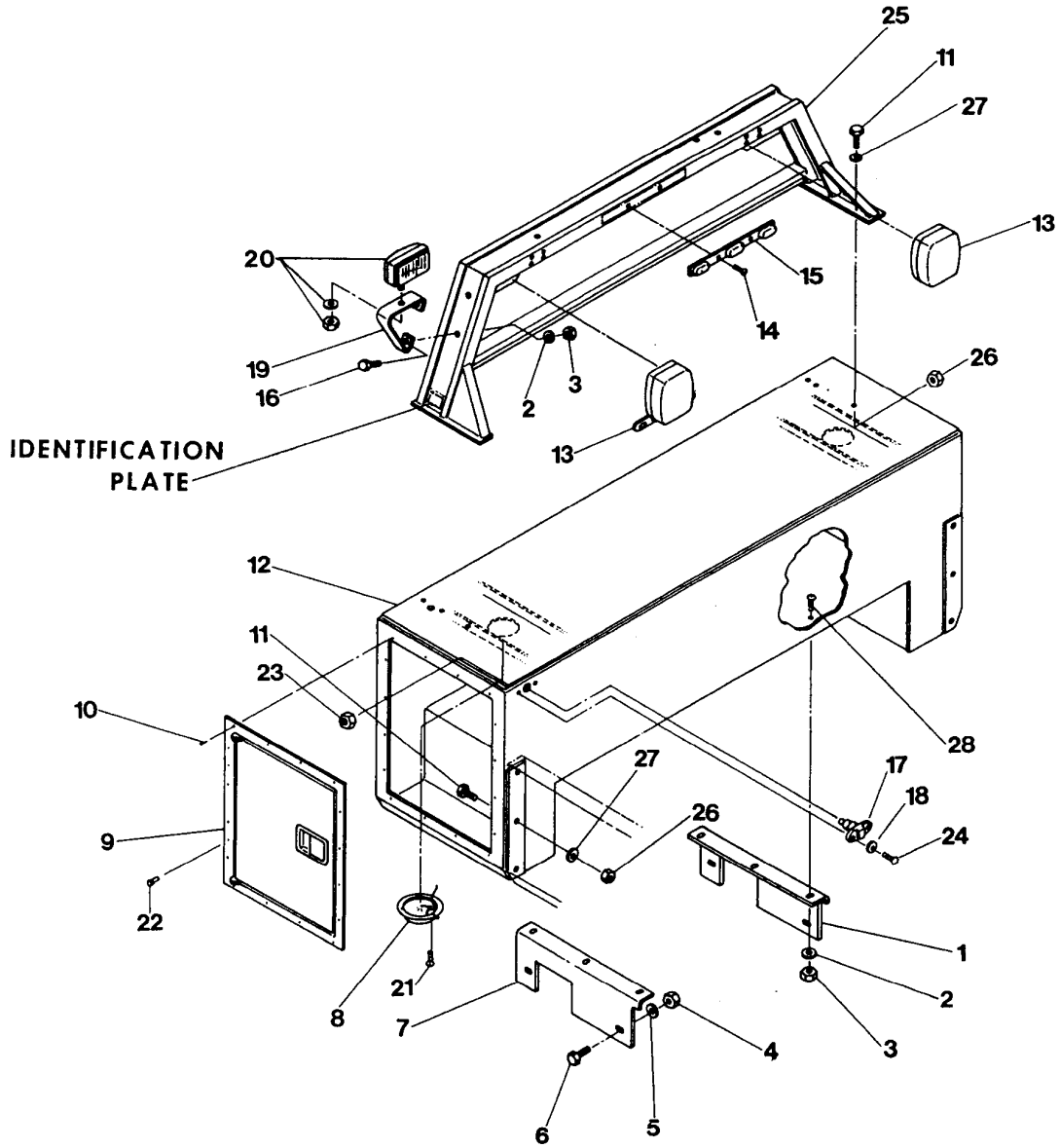

PARTS LIST — FOLD DOWN LIGHT BAR

Ref. No.	Part No.	Description	Qty.
1	C3-510-150025	Light Bar Weldment	1
2	B4-017-000129	Angle	2
3	B3-510-150080	Hinge Weldment	2
4	B4-017-000130	Angle	2
5	7-690-081441	Roll Pin	4
6	A7-949-000007	Flatwasher	4
7	7-114-140818	Screw, Button Head	8
8	7-114-141018	Screw, Button Head	8
9	A7-661-000006	Rubber, Well Nut	8
10	A4-706-000047	Spacer Plate	2
11	A3-413-000001	Light Bar Bolt	2
12	7-660-142600	Locknut, Nylok	8
13	A7-585-000001	Rubber Draw-Latch	2
14	A7-759-000002	Pop Rivet	8
15	7-111-101610	Screw, Round Head Machine	4
16	7-189-000001	Rubber Bumper	4
17	A7-661-000002	Nut w/Lockwasher	4
18	7-660-182601	Locknut, Nylok	2
19	7-950-180161	Flatwasher	2
20	7-950-140161	Flatwasher	8
21	A7-590-000008	Roof Bar Light	1

FOLD DOWN LIGHT BAR

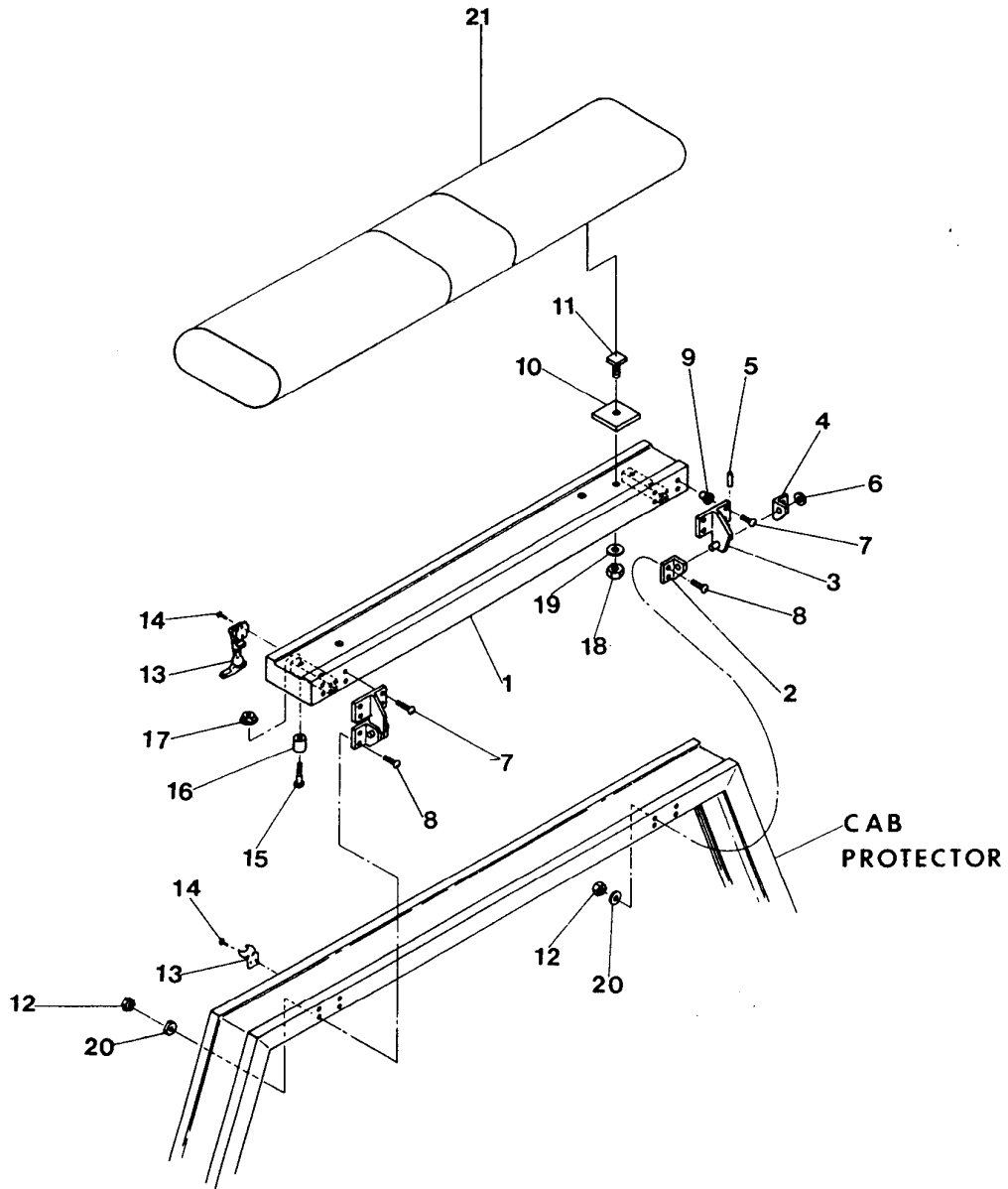

PARTS LIST — SUBFRAME

Ref. No.	Part No.	Description	Qty.
1	7-111-161050	Bolt, Hex Head	4
2	A4-497-000015	Gusset	4
3	3-831-000001	Spacer Weldment (Chevy — G.M.C. without Helper Springs) (G52)	2
	3-831-000002	Spacer Weldment (Chevy — G.M.C. w/Helper Springs) (G60)	2
	3-831-000005	Spacer Weldment (Chevy — G.M.C. 4 x 4)	2
4	7-950-160161	Flatwasher	4
5	7-660-162601	Locknut, Nylok	4
6	7-950-180161	Flat Washer	16
7	B4-706-000096	Mounting Plate	2
8	7-111-181850	Bolt, Hex Head	2
9	A7-189-000002	Rubber Bumper	2
10	7-660-182301	Locknut, Flanged	22
11	D3-510-700075	Brace Weldment	1
12	7-115-221650	Bolt, Hex Head	4
13	7-660-220001	Hex Nut	4
14	7-111-160650	Bolt, Hex Head	4
15	7-660-160000	Hex Nut	4
16	7-950-160000	Lockwasher	4
17	7-111-150850	Bolt, Hex Head	8
18	B4-178-000009	Mud Flap Bracket (L.H.)	1
	B4-178-000010	Mud Flap Bracket (R.H.)	1
19	D7-638-000001	Mud Flap	2
20	B4-706-000112	Back-Up Strip	2
21	7-950-150161	Flat Washer	16
22	7-660-152600	Locknut, Nylok	8
23	E3-510-700078	Subframe Weldment	1
24	7-115-181050	Bolt, Hex Head	12
25	A3-510-700010	Subframe Mount	2
26	7-115-201850	Bolt, Hex Head	2
27	A4-706-000001	Plate (Ford)	2
	A4-706-000071	Plate (Chevy — G.M.C.)	2
28	7-660-202601	Locknut, Nylok	2
29	7-950-200141	Flatwasher	2
30	C3-510-700011	Mounting Bracket (Fords w/Helper Springs and all Ford 4 x 4's)	2
	C3-510-700028	Mounting Bracket (Fords without Helper Springs)	2
31	3-831-000006	Spacer (All Fords)	2
32	7-115-181850	Bolt, Hex Head (Fords w/Helper Springs and all Ford 4 x 4's)	2
	7-115-183650	Bolt, Hex Head (Fords without Helper Springs)	2
33	4-178-000066	Mounting Bracket R.H. (Chevy — G.M.C.)	1

Rev. _____

51

Date _____

34	B3-178-000035	Mounting Bracket Weldment R.H. (Ford)	1
	4-178-000065	Mounting Bracket L.H. (Chevy — G.M.C.)	1
	B3-178-000036	Mounting Bracket Weldment L.H. (Ford)	1

JBF FRAME

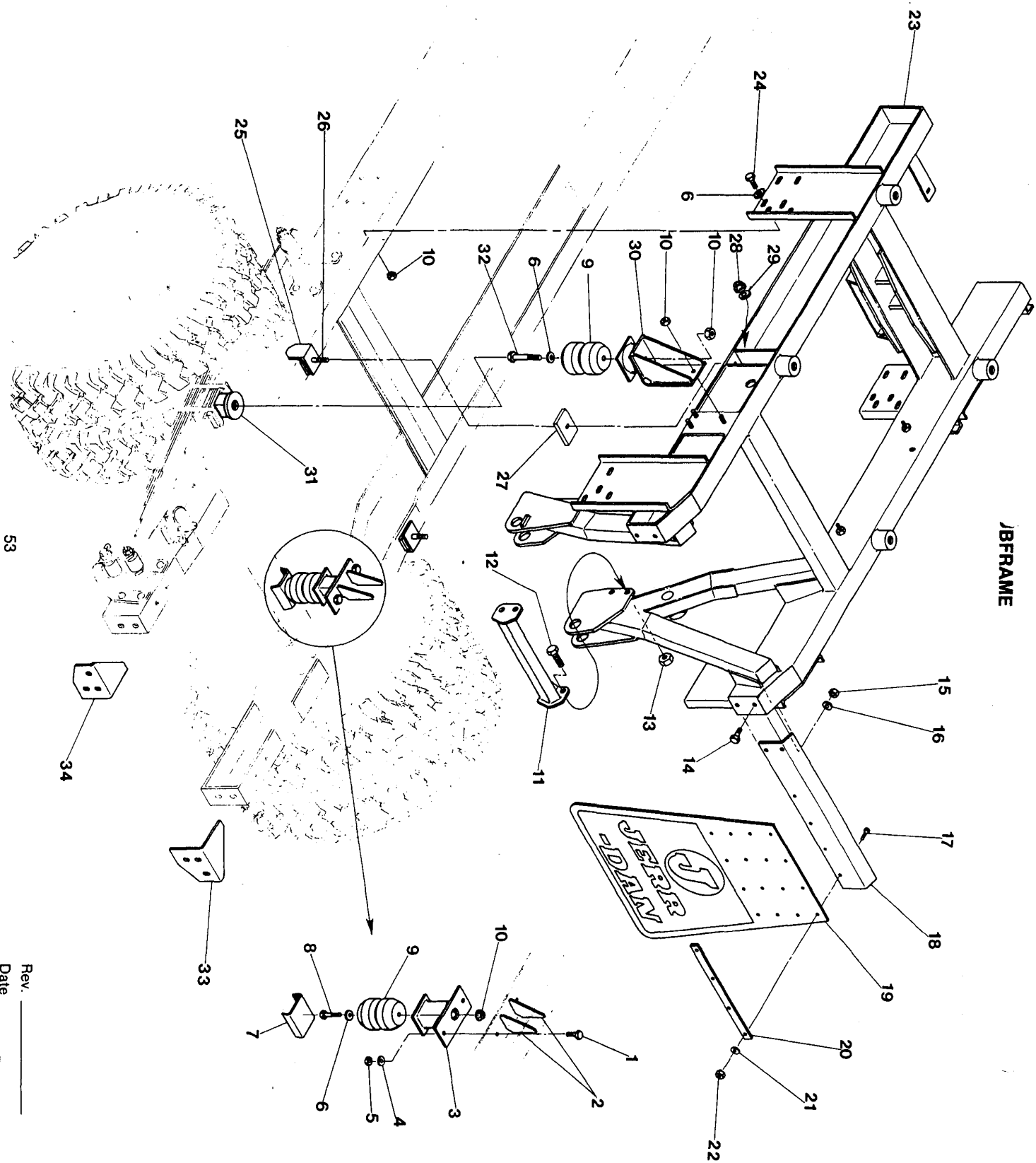

53

Rev. _____
Date _____

BOOM ASSEMBLY & INSTALLATION

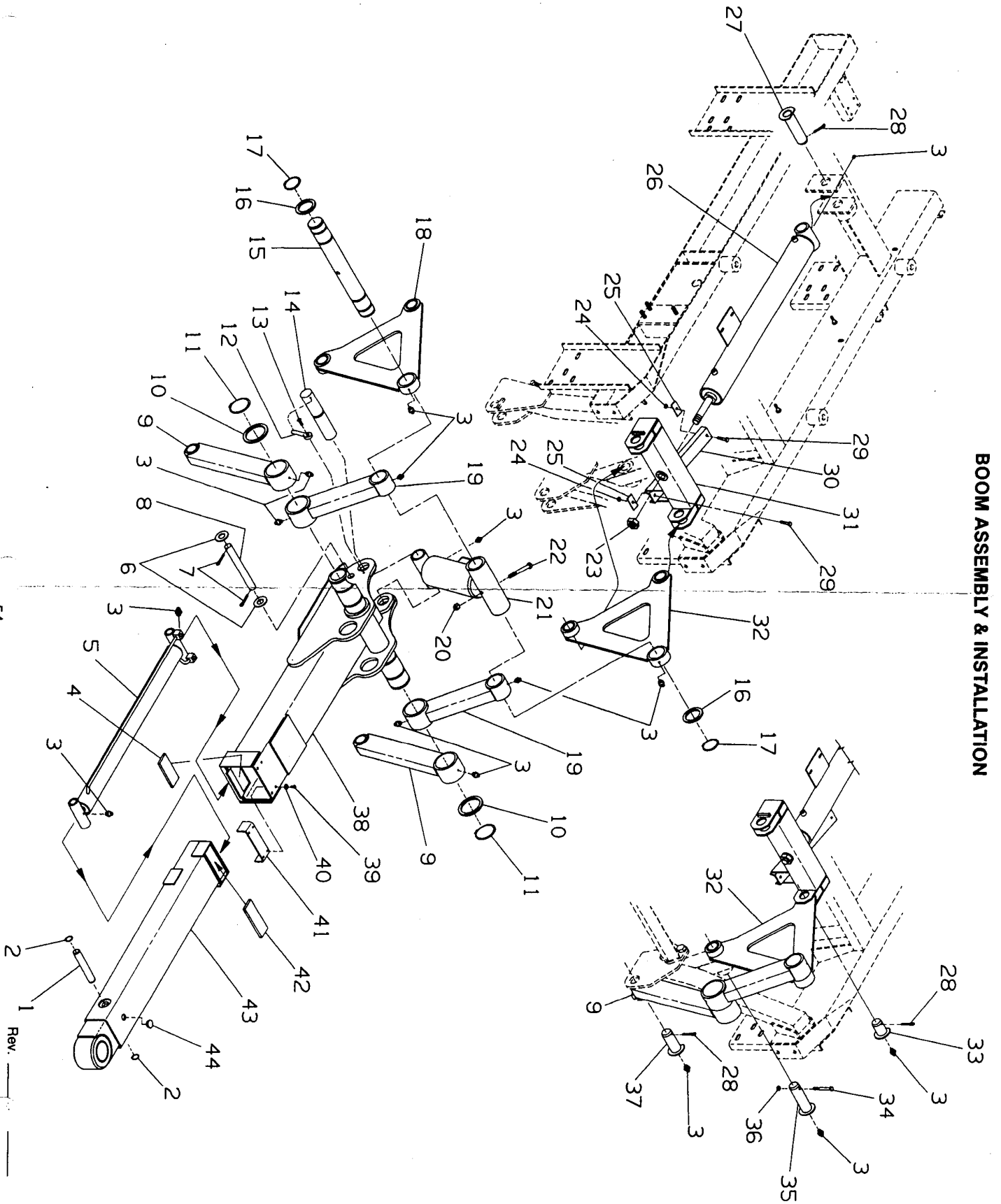

PARTS LIST — BOOM ASSEMBLY & INSTALLATION

Ref. No.	Part No.	Description	Qty.
1	B4-691-000056	Pin	1
2	A7-754-000019	Retaining Ring	2
3	7-440-030000	Grease Fitting	18
4	A4-679-000026	Nylatron Pad	1
5	C3-320-000017	Boom Ext. Cyl. Assy.	1
6	7-950-260251	Flatwasher	2
7	7-690-052410	Cotter Pin	2
8	B4-691-000053	Pin	1
9	B3-511-100007	Tube Weld.	2
10	A4-949-000018	Washer	2
11	A7-754-000018	Retaining Ring	2
12	A4-691-000036	Retainer Pin	1
13	7-118-150823	Fl. Hex Soc. Hd. Cap Screw	1
14	A4-691-000057	Pin	1
15	B4-691-000054	Pin	1
16	A4-949-000019	Washer	2
17	A7-754-000017	Retaining Ring	2
18	D3-511-100009	L.H. Arm Weld.	1
19	B3-511-100008	Tube Weld.	2
20	7-660-182600	Hex Nylok Nut	1
21	D3-320-000016	Boom Tilt Cyl. Assy.	1
22	7-115-183250	Hex Cap Screw	1
23	7-660-261630	Hex Lock Nut	1
24	7-660-152600	Hex Nylok Nut	2
25	A4-706-000416	Plate	2
26	C3-320-000014	Lift Cyl. Assy.	1
27	A3-691-000006	Pin Weld.	1
28	7-690-103210	Cotter Pin	5
29	7-111-151250	Hex Cap Screw	2
30	B3-511-100027	Hose Support Weld.	1
31	C3-510-100073	Lift Cyl. Yoke Weld.	1
32	D3-511-100010	R.H. Arm Weld.	1
33	A3-691-000007	Pin Weld.	2
34	7-111-162450	Hex Cap Screw	2
35	A3-691-000003	Pin Weld.	2
36	7-660-162601	Hex Nylok Nut	2
37	A3-691-000005	Pin Weld.	2
38	D3-511-100003	Boom Weld., Base Sect.	1
39	7-118-140418	Hex Soc. But. Hd. Cap Scr.	4
40	7-950-140161	Flatwasher	4
41	B4-263-000063	Channel	1
42	A4-679-000025	Nylatron Pad	1
43	D3-511-100004	Boom Weld., Fly Sect.	1
44	A7-701-000007	Plastic Plug	1

Rev. _____

Date _____

PARTS LIST — WHEEL GRID ASSEMBLY

Ref. No.	Part No.	Description	Qty.
1	A7-691-000011	Hitch Pin	2
2	A7-894-000002	Tie Down Strap	2
3	C3-511-880049	L — Arm	2
4	C3-511-880046	Grid Weldment R.H.	1
5	C3-511-880047	Grid Weldment L.H.	1
6	A4-691-000060	Pin	2
7	A3-178-000001	Anchor Bracket	2
8	7-105-182450	Hex Cap Screw	2
9	7-950-180153	Flatwasher	2
10	7-660-181630	Hex Locknut	2
11	B4-691-000059	Pin	1
12	C3-511-880001	Pivot Tube Weldment	1
13	7-118-160850	Hex Cap Screw	4
14	A7-701-000007	Plug	1
15	7-440-030000	Grease Fitting	3
16	A4-763-000045	Plastic Rod	2
17	A7-551-000005	T — Handle	2

WHEEL RID ASSEMBLY

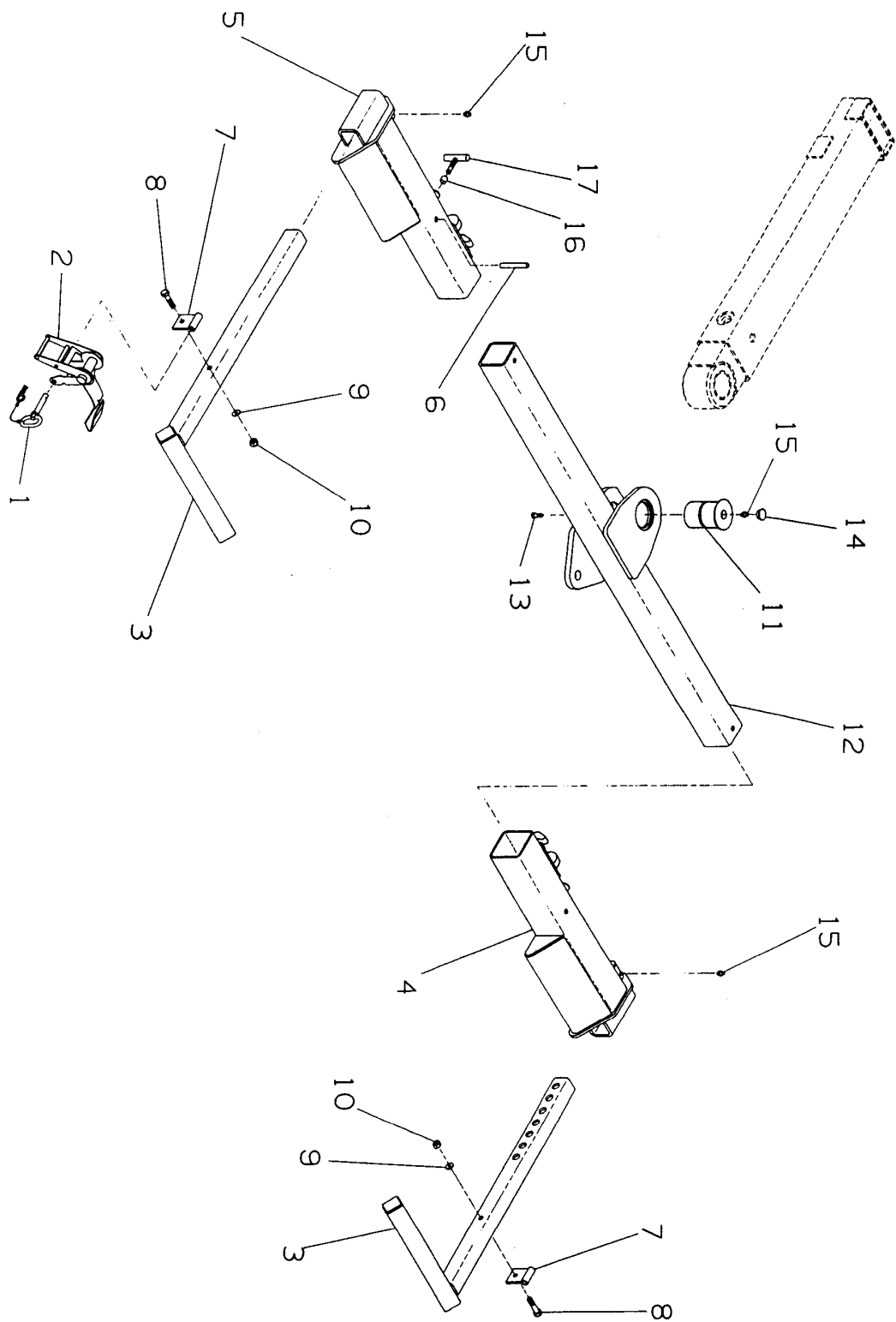

PARTS LIST — DECK MOUNTED WINCH

Ref. No.	Part No.	Description	Qty.
1	D3-510-900040	Winch Mount Weldment	1
2	C3-510-900069	Sheave Support Weldment	1
3	B3-510-900068	Cable Guide Weldment	1
4	A3-691-000002	Pin Weldment	1
5	A7-626-000003	Motor, Hydraulic	1
6	A7-970-000002	Winch	1
7	A7-248-000001	Cable Assembly	1
8	A7-754-000005	Ring, Retaining	1
9	7-111-181050	Bolt, Hex Head	2
10	7-950-180400	Washer, Lock	2
11	A7-754-000006	Ring, Retaining	1
12	A7-809-000001	Sheave	1
13	7-440-030000	Fitting, Grease	2
14	A7-551-000001	Knob, Ball	2
15	B4-763-000011	Rod, Control	2
16	B3-510-900041	Pivot Shaft Weldment	1
17	7-690-101645	Pin, Roll	2
18	7-111-162050	Bolt, Hex Head	3
19	7-660-162601	Nut, Hex Nylok	3
20	7-950-160161	Washer, Flat	3
21	A7-935-000002	Valve, Directional	1
22	A4-706-000084	Plate	2
23	7-690-000810	Pin, Cotter	2
24	7-690-141600	Pin, Clevis	2
25	C4-314-000004	Cover Plate	1
26	7-114-140823	Screw, Cap	6
27	A7-661-000006	Well-Nut	6
28	7-950-160161	Washer, Flat	10
29	7-950-160000	Washer, Lock	8
30	7-115-160850	Bolt, Hex Head	8
31	A4-209-000019	Bushing	2
32	7-115-241250	Bolt, Hex Head	4
33	7-950-240000	Washer, Lock	4

DECK MOUNTED WINCH

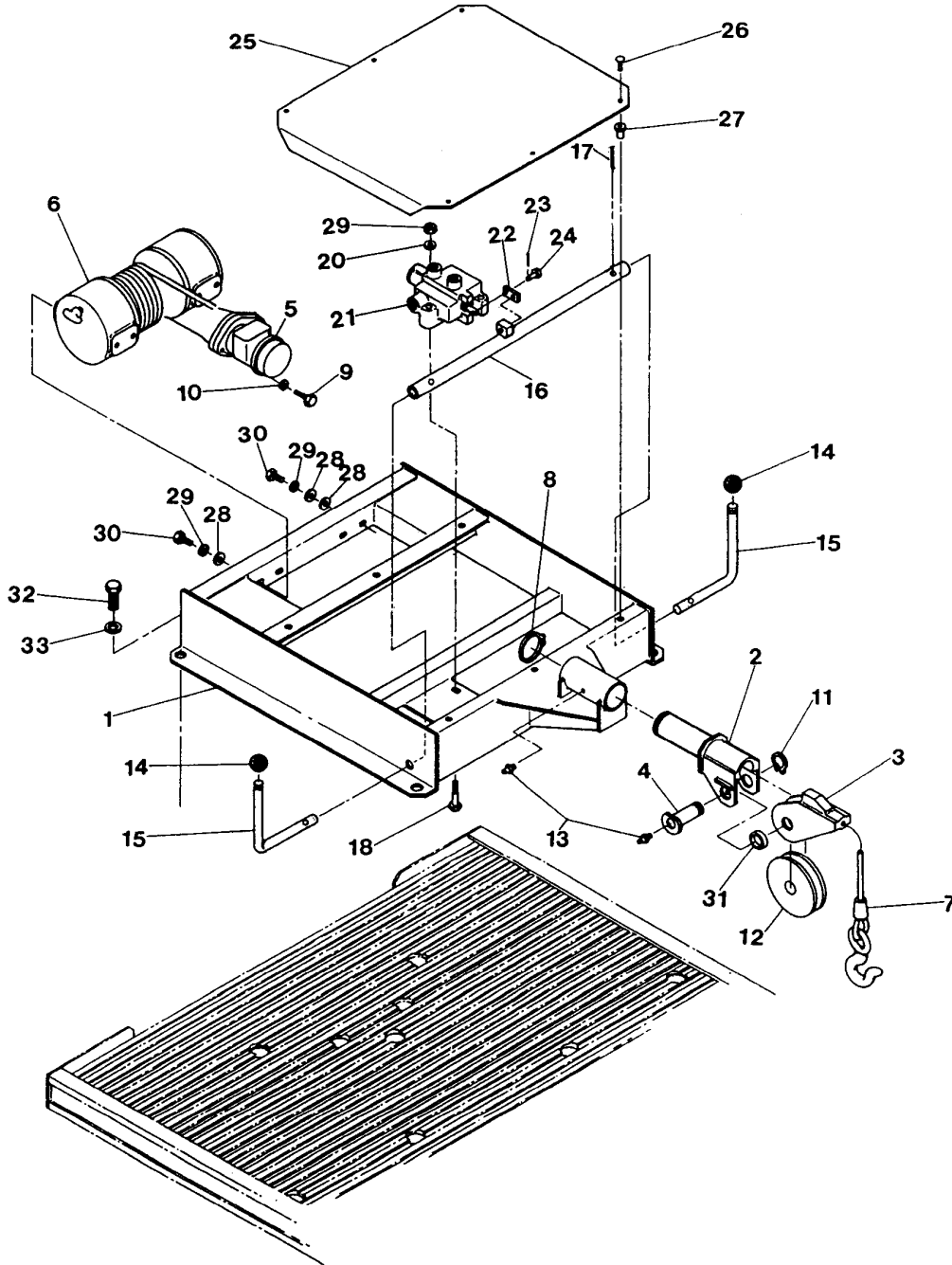

PARTS LIST — SINGLE WINCH WRECKER BOOM

Ref. No.	Part No.	Description	Qty.
1	7-660-152600	Lock Nut	14
2	7-950-150161	Flat Washer	8
3	A4-679-000009	Bearing Pad	1
4	7-111-150813	Truss Head Machine Screw	2
5	7-111-140850	Hex Head Bolt	3
6	A7-765-000001	Rod End	3
7	7-660-140230	Hex Jam Nut	3
8	7-660-142600	Lock Nut	3
9	A7-935-000001	Valve, Counterbalance	1
10	7-111-151650	Bolt, Hex Head	2
11	A4-679-000007	Bearing Pad	2
12	D3-551-000005	Control Handle Weldment	1
13	7-111-151213	Truss Head Machine Screw	4
14	D3-510-100055	Control Channel Weldment	1
15	3-763-000005	Rod Weldment	1
16	3-763-000006	Rod Weldment	1
17	3-763-000004	Rod Weldment	1
18	7-115-161050	Hex Head Bolt	4
19	7-950-160161	Flat Washer	20
20	D3-510-100052	Base Weldment	1
21	B4-691-000029	Pin	4
22	7-950-140000	Lockwasher	3
23	D3-510-100060	Wrecker Boom Fly Section	1
24	A7-701-000006	Hole Plug	2
25	A4-949-000009	Washer	2
26	7-660-162601	Hex Locknut, Nylok	4
27	D3-510-100050	Single Winch Mount Weldment	1
28	D3-510-100062	Wrecker Boom Base Section	1
29	7-950-160000	Lock Washer	8
30	7-115-160850	Hex Head Bolt	8
31	A7-970-000005	Winch	1
32	D3-510-100058	Boom Nose Weldment	1
33	B4-691-000030	Pin	2
34	4-691-000028	Pin	1
35	7-118-151223	Cap Screw	6
36	A4-691-000036	Pin Retainer	6
37	7-118-140423	Cap Screw	2
38	A4-706-000067	Plate	1
39	D3-320-000007	Ext. Cylinder Assembly	1
40	D3-320-000012	Cylinder, Lift R.H.	1
41	D3-320-000011	Cylinder, Lift L.H.	1
42	7-690-000810	Cotter Pin	3
43	7-690-141200	Clevis Pin	3
44	A4-679-000005	Wear Pad	1
45	4-314-000008	Cover Plate	1
46	7-111-140613	Truss Head Screw	3
47	7-115-244050	Hex Head Bolt	4
48	7-950-240161	Flat Washer	4
49	A7-551-000001	Ball Knob	6
50	3-551-000006	Control Handle Weldment	1

Rev. _____

Date _____

51	3-551-000007	Control Handle Weldment	1
52	A7-754-000006	Retaining Ring	6
53	A4-679-000004	Wear Pad	1
54	A4-706-000160	Plate	1
55	7-950-180000	Lock Washer	2
56	7-115-180850	Hex Head Bolt	2
57	4-691-000027	Pin	1
58	7-115-181450	Hex Head Bolt	4
59	7-950-220141	Flatwasher	2
60	7-690-102045	Roll Pin	2
61	A4-691-000026	Pin	1
62	7-660-182600	Lock Nut	4
63	A3-510-100057	Lug Weldment	1
64	7-440-030000	Grease Fitting	4
65	A3-691-000002	Pin Weldment	1
66	A7-809-000001	Sheave	1
67	A7-248-000003	Cable Assy.	1
68	A7-754-000005	Retaining Ring	1
69	B3-510-900068	Cable Guide Weldment	1
70	A4-209-000019	Bushing	2
71	C3-510-900069	Sheave Support Weldment	1
72	A7-626-000003	Motor, Hydraulic	1
73	7-111-181050	Hex Head Bolt	2
74	7-950-180400	Lockwasher	2

SINGLE WINCH WRECKER BOOM

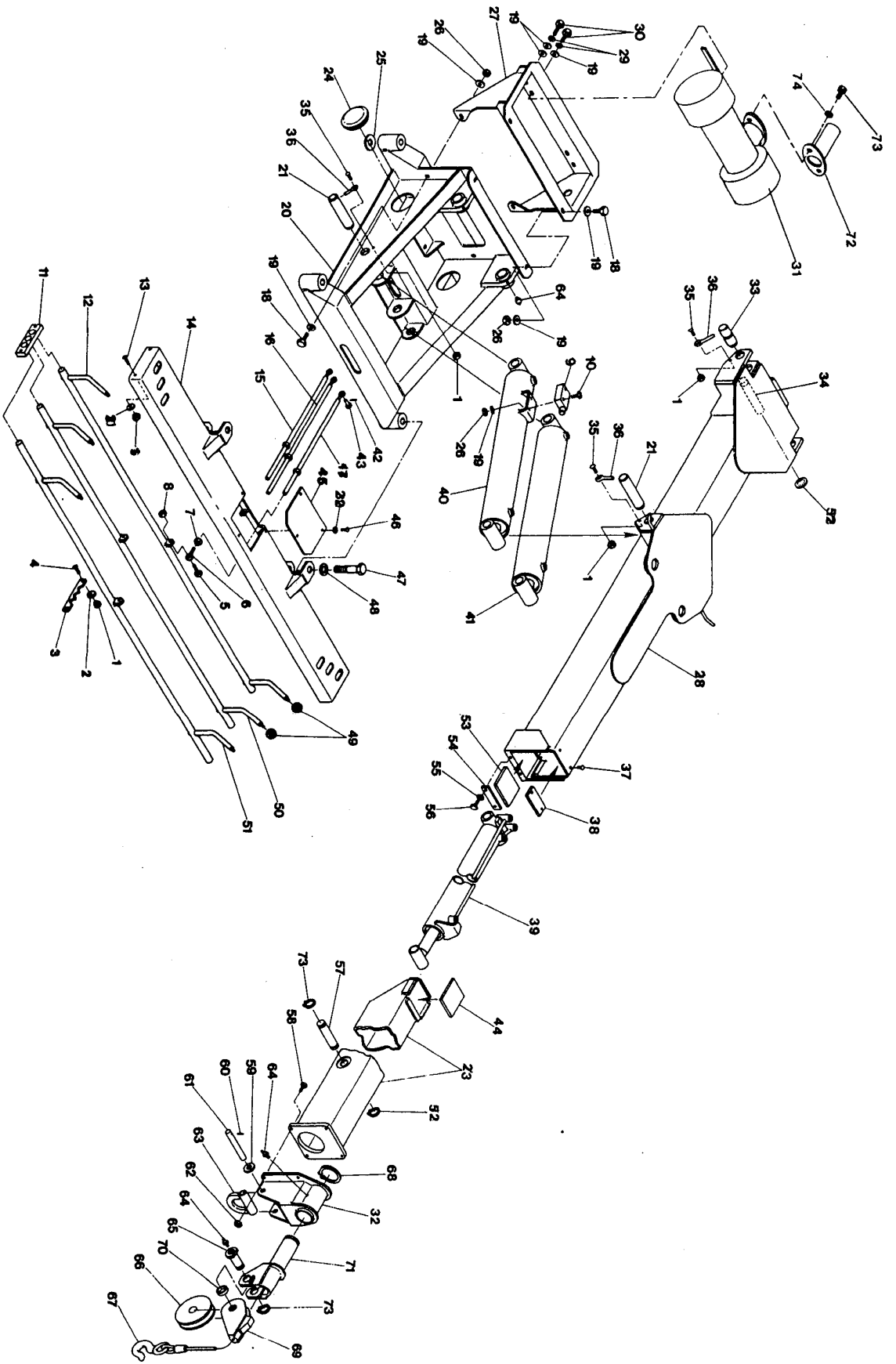

DUAL WINC /RECKER BOOM

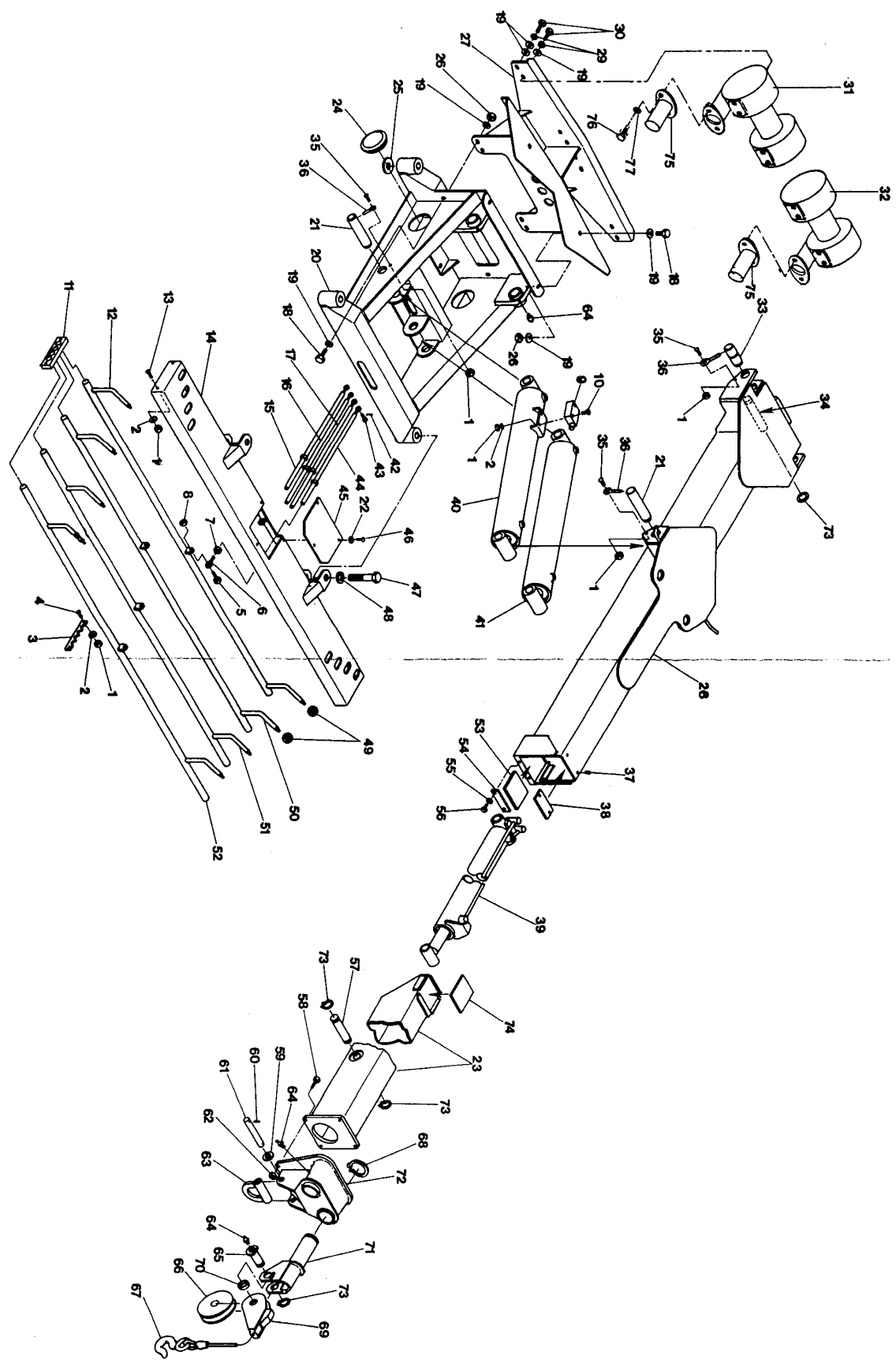

PARTS LIST — DUAL WINCH WRECKER BOOM

Ref. No.	Part No.	Description	Qty.
1	7-660-152600	Lock Nut	14
2	7-950-150161	Flatwasher	8
3	A4-679-000010	Bearing Pad	1
4	7-111-150813	Truss Head Machine Screw	2
5	7-111-140850	Hex Head Bolt	4
6	A7-765-000001	Rod End	4
7	7-660-140230	Hex Jam Nut	4
8	7-660-142600	Lock Nut	4
9	A7-935-000001	Valve, Counterbalance	1
10	7-111-151650	Bolt, Hex Head	2
11	A4-679-000008	Bearing Pad	2
12	D3-551-000005	Control Handle Weldment	1
13	7-111-151213	Truss Head Machine Screw	4
14	D3-510-100055	Control Channel Weldment	1
15	3-763-000005	Rod Weldment	1
16	3-763-000007	Rod Weldment	1
17	3-763-000006	Rod Weldment	1
18	7-115-161050	Hex Head Bolt	6
19	7-950-160161	Flat Washer	32
20	D3-510-100052	Base Weldment	1
21	B4-691-000029	Pin	4
22	7-950-140000	Lockwasher	3
23	D3-510-100060	Wrecker Boom Fly Section	1
24	A7-701-000006	Hole Plug	2
25	A4-949-000009	Washer	2
26	7-660-162601	Hex Locknut, Nylok	6
27	D3-510-100051	Dual Winch Mount Weldment	1
28	D3-510-100062	Wrecker Boom Base Section	1
29	7-950-160000	Lock Washer	16
30	7-115-160850	Hex Head Bolt	16
31	A7-970-000005	Winch L.H.	1
32	A7-970-000004	Winch R.H.	1
33	B4-691-000030	Pin	2
34	4-691-000028	Pin	1
35	7-118-151223	Cap Screw	6
36	A4-691-000036	Pin Retainer	6
37	7-118-140423	Cap Screw	2
38	A4-706-000067	Plate	1
39	D3-320-000007	Ext. Cylinder Assembly	1
40	D3-320-000012	Cylinder, Lift R.H.	1
41	D3-320-000011	Cylinder, Lift L.H.	1
42	7-690-000810	Cotter Pin	4
43	7-690-141200	Clevis Pin	4
44	3-763-000004	Rod Weldment	1
45	4-314-000008	Cover Plate	1
46	7-111-140613	Truss Head Screw	3
47	7-115-244050	Hex Head Bolt	4
48	7-950-240161	Flat Washer	4
49	A7-551-000001	Ball Knob	8
50	3-551-000006	Control Handle Weldment	1

Rev. _____

Date _____

51	3-551-000007	Control Handle Welment	1
52	3-551-000008	Control Handle Weldment	1
53	A4-679-000004	Wear Pad	1
54	A4-706-000160	Plate	1
55	7-950-180000	Lock Washer	2
56	7-115-180850	Hex Head Bolt	2
57	4-691-000027	Pin	1
58	7-115-181450	Hex Head Bolt	4
59	7-950-220141	Flat Washer	2
60	7-690-102045	Roll Pin	2
61	A4-691-000026	Pin	1
62	7-660-182600	Lock Nut	4
63	A3-510-100057	Lug Weldment	1
64	7-440-030000	Grease Fitting	6
65	A3-691-000002	Pin Weldment	2
66	A7-809-000001	Sheave	2
67	A7-248-000003	Cable Assembly	2
68	A7-754-000005	Retaining Ring	2
69	B3-510-900068	Cable Guide Weldment	2
70	A4-209-000019	Bushing	4
71	C3-510-900069	Sheave Support Weldment	2
72	D3-510-100059	Boom Nose Weldment	1
73	A7-754-000006	Retaining Ring	6
74	A4-679-000005	Wear Pad	1
75	A7-626-000003	Motor, Hydraulic	2
76	7-111-181050	Hex Head Bolt	4
77	7-950-180400	Lock Washer	4

PARTS LIST — TOW SLING ASSEMBLY

Ref. No.	Part No.	Description	Qty.
1	A7-804-000001	Shackle, Anchor	1 or 2
2	B4-706-000254	Plate, Anchor	1
3	B3-178-000026	Anchor Plate Weldment	1
4	A4-706-000253	Plate	2
5	9-259-870002	Casting, Swivel	1
6	9-706-870001	Plate, Skid	1
7	9-902-870002	Bottom Anchor Weldment	1
8	A7-822-000003	Belt, Sling	2
9	7-111-161250	Bolt, Hex Head	6
	7-660-161603	Nut, Lock	6
10	7-101-222850	Bolt, Hex Head	2
	7-660-221630	Nut, Lock	2
11	A7-822-000005	Hold Back Bar Assembly	2
12	7-105-222450	Bolt, Hex Head	2
	7-660-221630	Nut, Lock	2
13	9-691-870006	Pin, Roll	4
14	9-843-870007	Spring, Lock Pin	1
15	9-551-870007	Handle, Lock	1
16	9-691-870007	Plunger, Lock	1
17	9-071-870001	Barrel, Lock	1
18*	9-551-870008	Handle Assembly	2
19	9-706-000002	Saddle	1
20	A7-691-000009	Pin, Hitch	2
21	B3-309-000002	U-Joint Weldment	2
22	A7-822-000007	Bracket, Body	4
23	A7-262-000010	Chain Assembly	2
24	7-111-163250	Bolt, Hex Head	6
	7-660-161603	Nut, Lock	6
25	7-115-181450	Bolt, Hex Head	8
	7-660-182301	Nut, Flanged Lock	8
	7-950-180201	Washer, Flat	8
26*	A7-822-000004	Bottom Anchor Assembly	1

* — Handle assembly (18) contains two each of 13,
one each of 14, 15, 16 & 17.

* — Bottom anchor assembly (26) contains one each of 5, 6, & 7.

Rev. _____

Date _____

TOW SLING ASSEMBLY

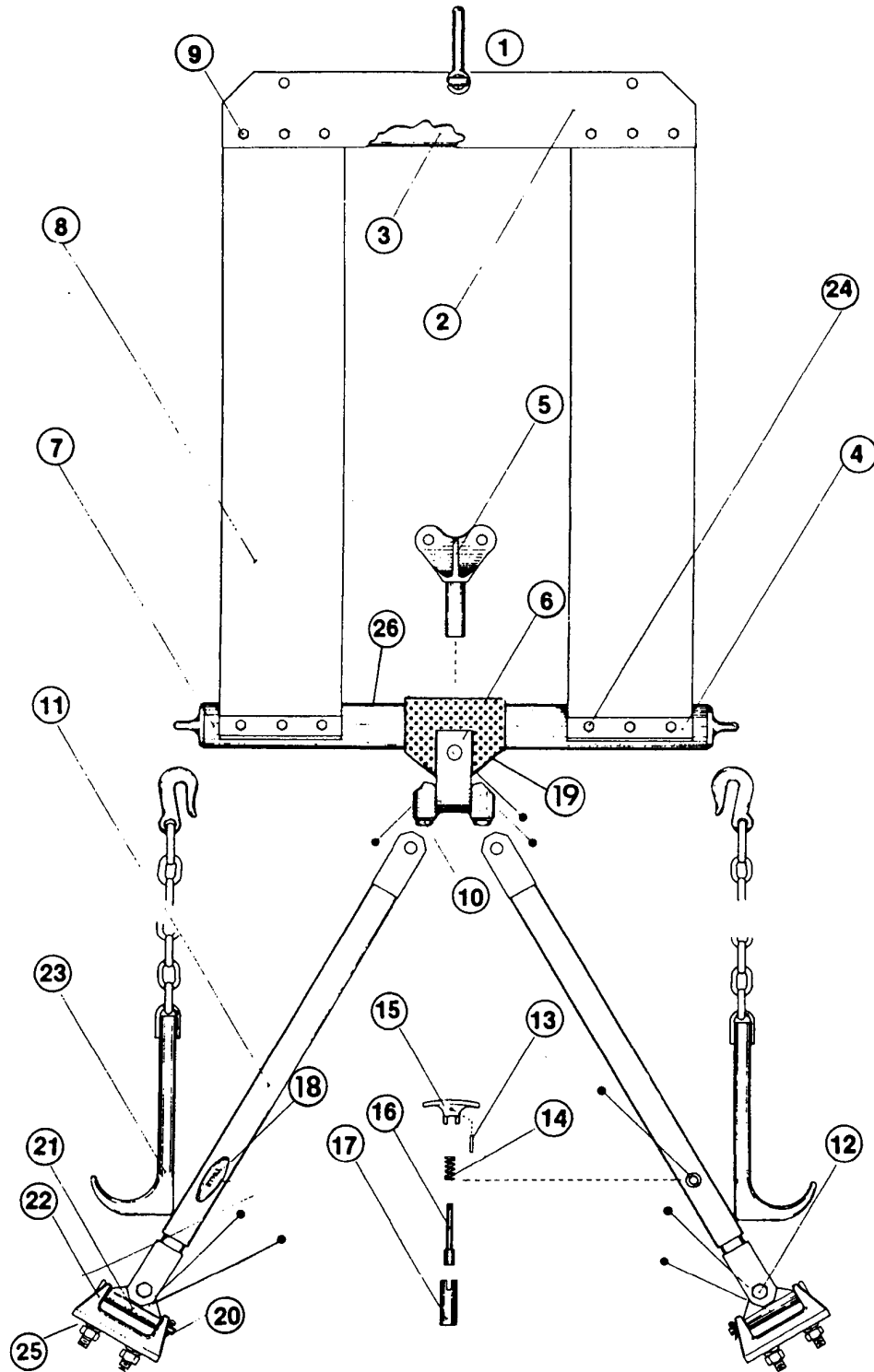

PARTS LIST — TOW SLING INSTALLATION

Ref. No.	Part No.	Description	Qty.
1	C3-178-000066	L.H. Tow Sling Bracket	1
	C3-178-000067	R.H. Tow Sling Bracket	1
2	7-115-181450	Hex Head Bolt	6
3	A7-691-000009	Hitch Pin w/Hair Pin	2
4	7-440-030000	Grease Fitting	4
5	B3-309-000003	U-Joint Weldment	2
6	7-105-222450	Hex Head Bolt	2
7	7-660-221630	Locknut	2
8	7-660-182301	Flanged Locknut	6
9	A7-679-000013	Rubber Pad	2
*10	B4-178-000109	Storage Bracket	2
*11	7-115-181450	Hex Head Bolt	4
*12	B4-706-000347	Back-Up Plate	2
*13	7-660-182301	Flanged Locknut	4
*14	7-262-000012	Safety Chains	2

* Items indicated are optional equipment.

TOW SLING INSTALLATION

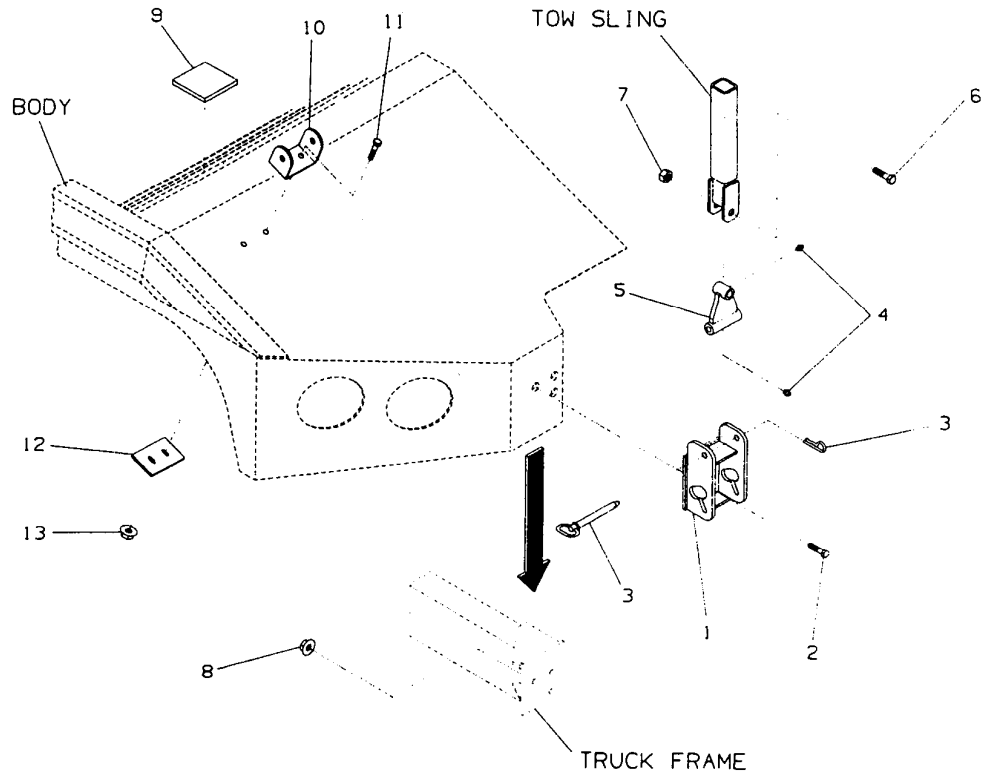

PARTS LIST — ALUMINUM PUSH BUMPER

Ref. No.	Part No.	Description	Qty.
1	A4-706-000205	Mounting Bar	4
2	D3-190-000002	Bumper	1
3	7-660-180161	Flat Bar	16
4	7-660-182301	Hex Nut, Flanged	8
5	B3-178-000014	Frame Bracket L.H. (Chevy)	1
	B3-178-000012	Frame Bracket L.H. (Ford)	1
	C3-178-000030	Frame Bracket L.H. (Ford 4 x 4)	1
6	7-105-201450	Hex Head Bolt	4
7	7-950-200161	Washer	4
8	7-660-202331	Hex Nut, Flanged	4
9		Insulator	
10	7-950-160161	Flatwasher	6
11	7-660-162601	Hex Nut	6
12	B3-178-000015	Frame Bracket R.H. (Chevy)	1
	B3-178-000013	Frame Bracket R.H. (Ford)	1
	C3-178-000031	Frame Bracket R.H. (Ford 4 x 4)	1
13	7-115-161250	Hex Head Bolt	6
14	A7-189-000004	Rubber Bumper	4
15	7-115-181450	Hex Head Capscrew	8
16	D3-495-000001	Grill Guard (Ford & Chevy — 2 x 4)	1
	D3-495-000002	Grill Guard (Ford 4 x 4)	1

TRUCK FRAME

ALUMI. M. PUSH BUMPER

CHEVY

FORD

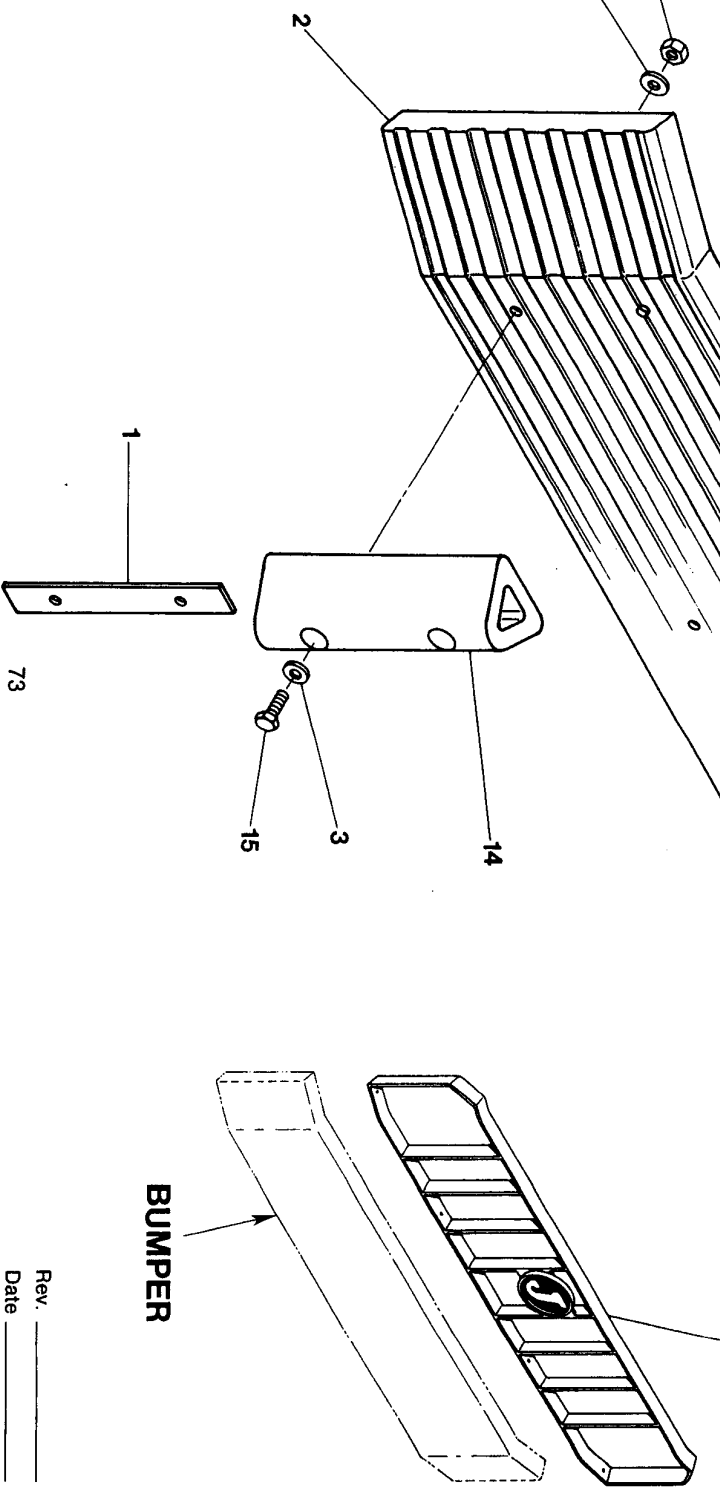
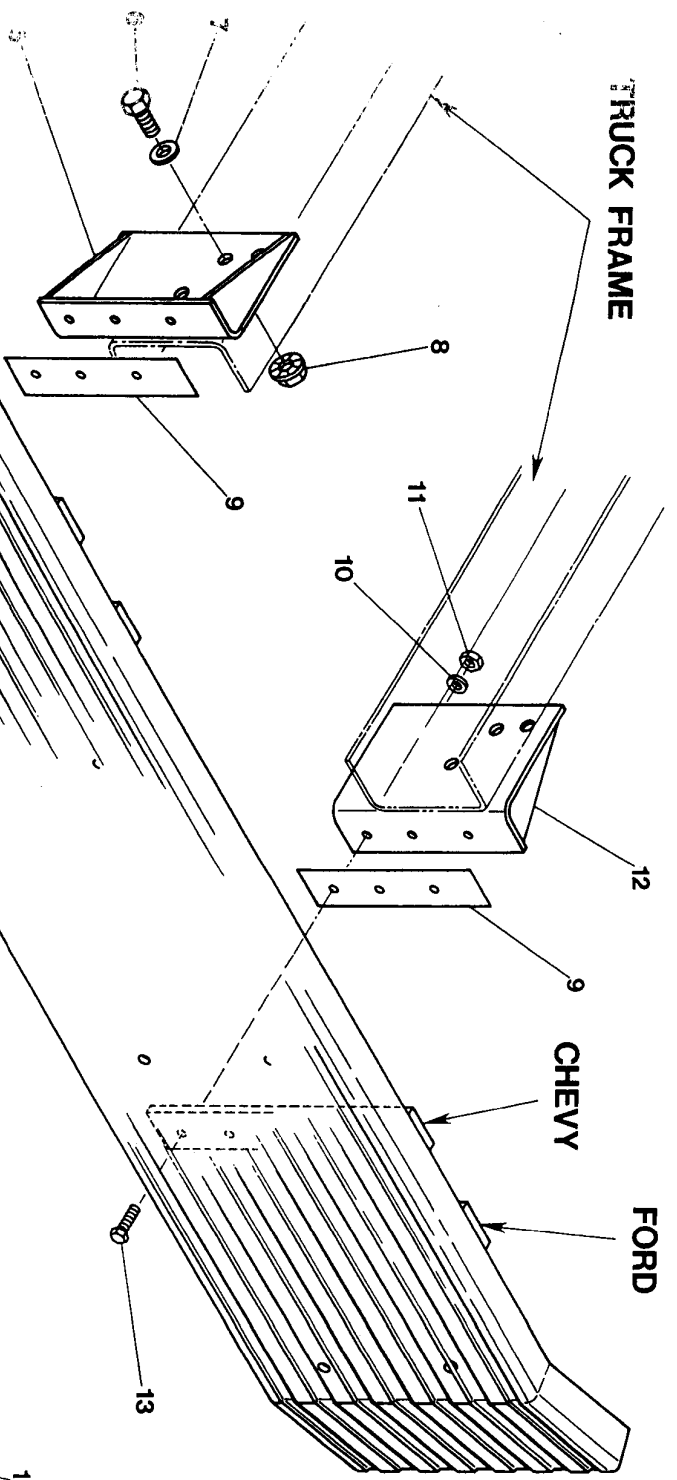

73

Rev. _____
 Date _____

RAMSEY WINCH #121704

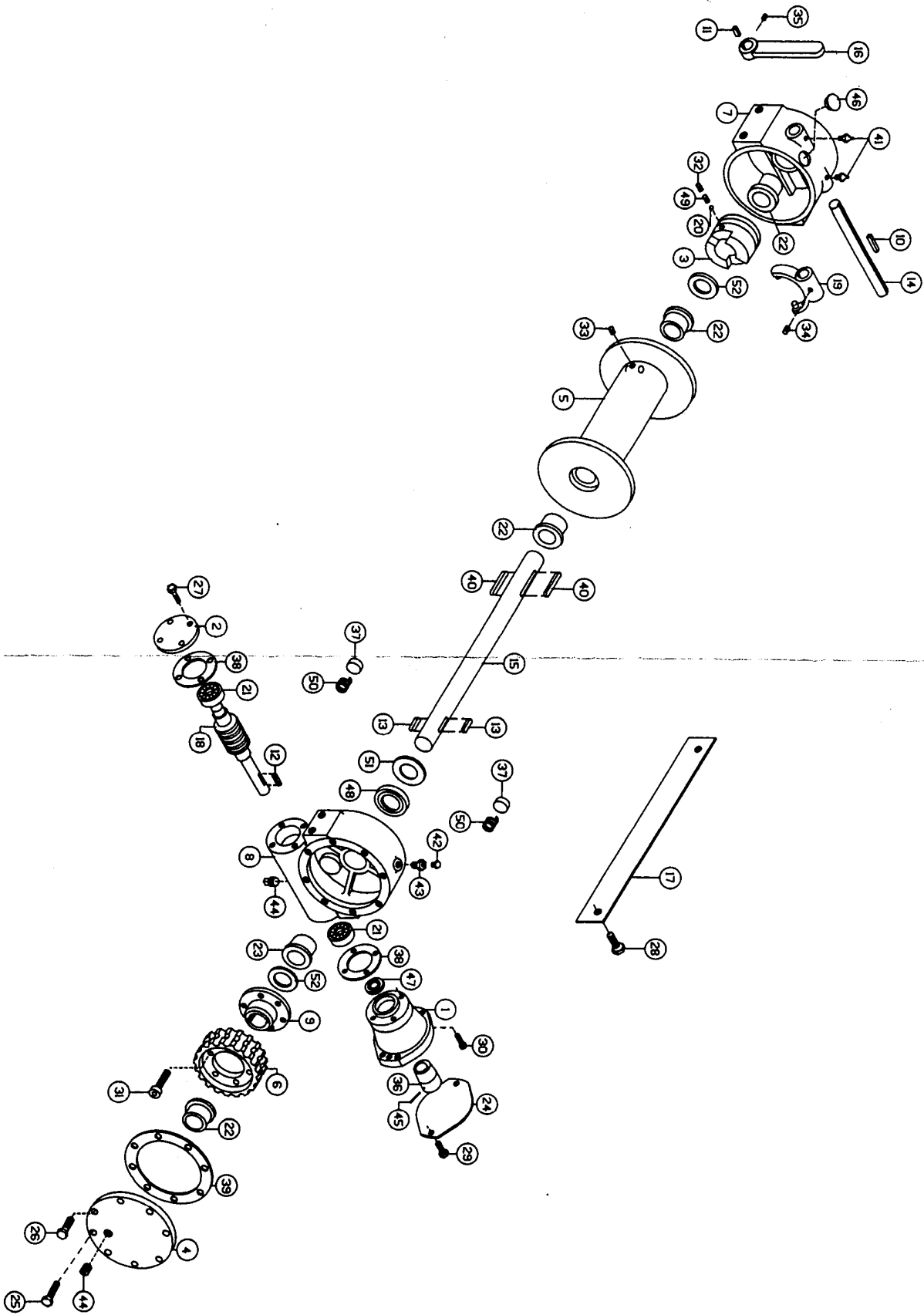

PARTS LIST — RAMSEY WINCH 121704

Ref. No.	Part No.	Description	Qty.
1	300057	Adapter	1
2	316083	Bearing Cap	1
3	324161	Jaw Clutch	1
4	328105	Cover	1
5	332105	Drum	1
6*	334004	Gear R.H. 60:1	1
7	338003	Housing — Clutch	1
8	338237	Housing — Gear	1
9*	340071	Hub — Gear	1
10	342019	Key	1
11	342024	Key	1
12	342027	Key	1
13	342075	Key	2
14	356902	Shaft — Shift	1
15	357463	Shaft — Drum — "Std."	1
16	358052	Lever — Shift	1
17	364017	Strap — Shipping	1
18	368007	Worm R.H. 60:1	1
19	370001	Yoke	1
20	400001	Ball — Poppet	1
21	402002	Bearing — Ball	2
22	412003	Bushing	4
23	412045	Bushing	1
24	413013	Cover — Adapter	1
25	414020	Capscrew 1/4-20NCx3/4 Lg. Hx. Hd. Gr.5 Nylok Hvy. Patch	1
26	414038	Capscrew 1/4-20NCx3/4 Lg. Hx. Hd. Gr.5	7
27	414045	Capscrew 1/4-20NCx7/8 Lg. Hx. Hd. Gr.5	4
28	414230	Capscrew 3/8-16NCx1/2 Lg.	2
29	414521	Capscrew 1/2-13NCx1 Lg.	2
30	414842	Capscrew 1/4-20NCx1 1/4 Lg. Soc. Hd. Lok-Wel.	4
31*	414889	Capscrew 5/16-18NCx3/4 Lg. Soc. Hd. (Torx Hd. Sems Unit)	6
32	416040	Setscrew 5/16-18NCx1/4 Lg. Hx. Soc. Hd. Cup Pt.	1
33	416059	Setscrew 3/8-16NCx1/2 Lg. Hx. Soc. Hd. Cup Pt.	1
34	416084	Setscrew 1/4-20NCx1/2 Lg. Sq. Hd. Cup Pt.	1
35	416112	Setscrew 5/16-18NCx3/4 Lg. Sq. Hd. Cup Pt.	1
36	431008	Coupling	1
37	438014	Disc — Brake	2
38	442184	Gasket	2
39	442188	Gasket	1
40	450006	Key — Barth	2
41	456006	Fitting — Lube	2

42	456008	Fitting — Relief	1
43	468002	Reducer	1
44	468011	Plug — Pipe	2
45	470033	Spirol Pin	1
46	472013	Plug — Plastic	1
47	486009	Oil Seal	1
48	486017	Oil Seal	1
49	494001	Spring	1
50	494002	Spring	2
51	518014	Thrust Washer	1
52	518015	Thrust Washer	2

NOTE — Items marked with an asterisk (*) cannot be purchased as individual parts. These parts are factory set and sold as an assembly only. Gear/hub assembly part number is 250501 R.H. 60:1.

PARTS LIST — RAMSEY WINCH 121705

Ref. No.	Part No.	Description	Qty.
1	300057	Adapter	1
2	316083	Bearing Cap	1
3	324161	Jaw Clutch	1
4	328105	Cover	1
5	332105	Drum	1
6*	334004	Gear R.H. 60:1	1
7	338003	Housing — Clutch	1
8	338237	Housing — Gear	1
9*	340071	Hub — Gear	1
10	342019	Key	1
11	342024	Key	1
12	342027	Key	1
13	342075	Key	2
14	356902	Shaft — Shift	1
15	357463	Shaft — Drum — "Std."	1
16	358052	Lever — Shift	1
17	364017	Strap — Shipping	1
18	368007	Worm R.H. 60:1	1
19	370001	Yoke	1
20	400001	Ball — Poppet	1
21	402002	Bearing — Ball	2
22	412003	Bushing	4
23	412045	Bushing	1
24	413013	Cover — Adapter	1
25	414020	Capscrew 1/4-20NCx3/4 Lg. Hx. Hd. Gr.5 Nylok Hvy. Patch	1
26	414038	Capscrew 1/4-20NCx3/4 Lg. Hx. Hd. Gr.5	7
27	414045	Capscrew 1/4-20NCx7/8 Lg. Hx. Hd. Gr.5	4
28	414230	Capscrew 3/8-16NCx1/2 Lg.	2
29	414521	Capscrew 1/2-13NCx1 Lg.	2
30	414842	Capscrew 1/4-20NCx1 1/4 Lg. Soc. Hd. Lok-Wel	4
31*	414889	Capscrew 5/16-18NCx3/4 Lg. Soc. Hd. (Torx Hd. Sems Unit)	6
32	416040	Setscrew 5/16-18NCx1/4 Lg. Hx. Soc. Hd. Cup Pt.	1
33	416059	Setscrew 3/8-16NCx1/2 Lg. Hx. Soc. Hd. Cup Pt.	1
34	416084	Setscrew 1/4-20NCx1/2 Lg. Sq. Hd. Cup Pt.	1
35	416112	Setscrew 5/16-18NCx3/4 Lg. Sq. Hd. Cup Pt.	1
36	431008	Coupling	1
37	438014	Disc — Brake	2
38	442184	Gasket	2
39	442188	Gasket	1
40	450006	Key — Barth	2
41	456006	Fitting — Lube	2

Rev. _____

Date _____

42	456008	Fitting — Relief	1
43	468002	Reducer	1
44	468011	Plug — Pipe	2
45	470033	Spirol Pin	1
46	472013	Plug — Plastic	1
47	486009	Oil Seal	1
48	486017	Oil Seal	1
49	494001	Spring	1
50	494002	Spring	2
51	518014	Thrust Washer	1
52	518015	Thrust Washer	2

NOTE — Items marked with an asterisk (*) cannot be purchased as individual parts. These parts are factory set and sold as an assembly only. Gear/hub assembly part number is 250501 R.H. 60:1.

RAM WINCH #121705

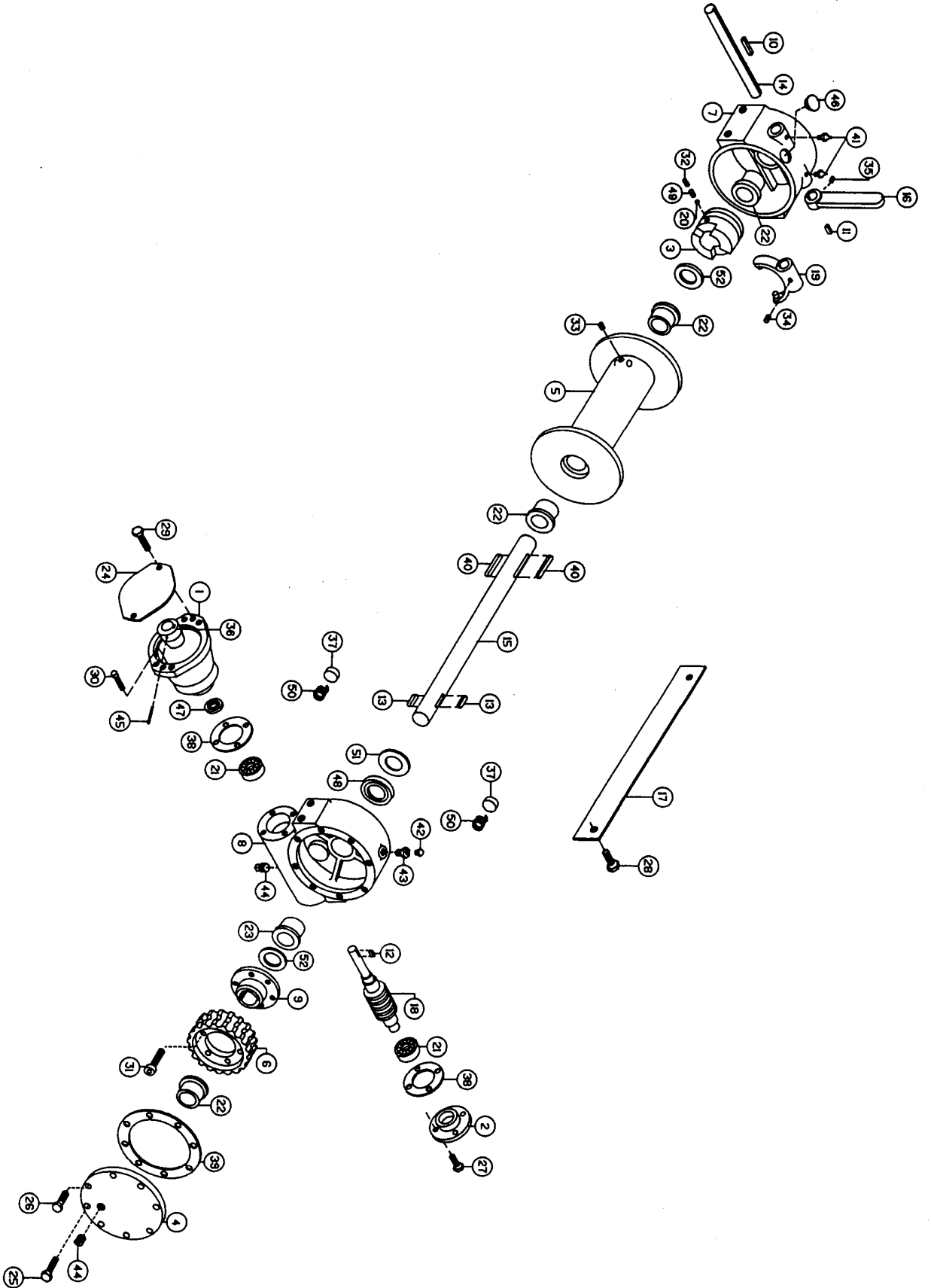

RAMSEY WINCH #121696

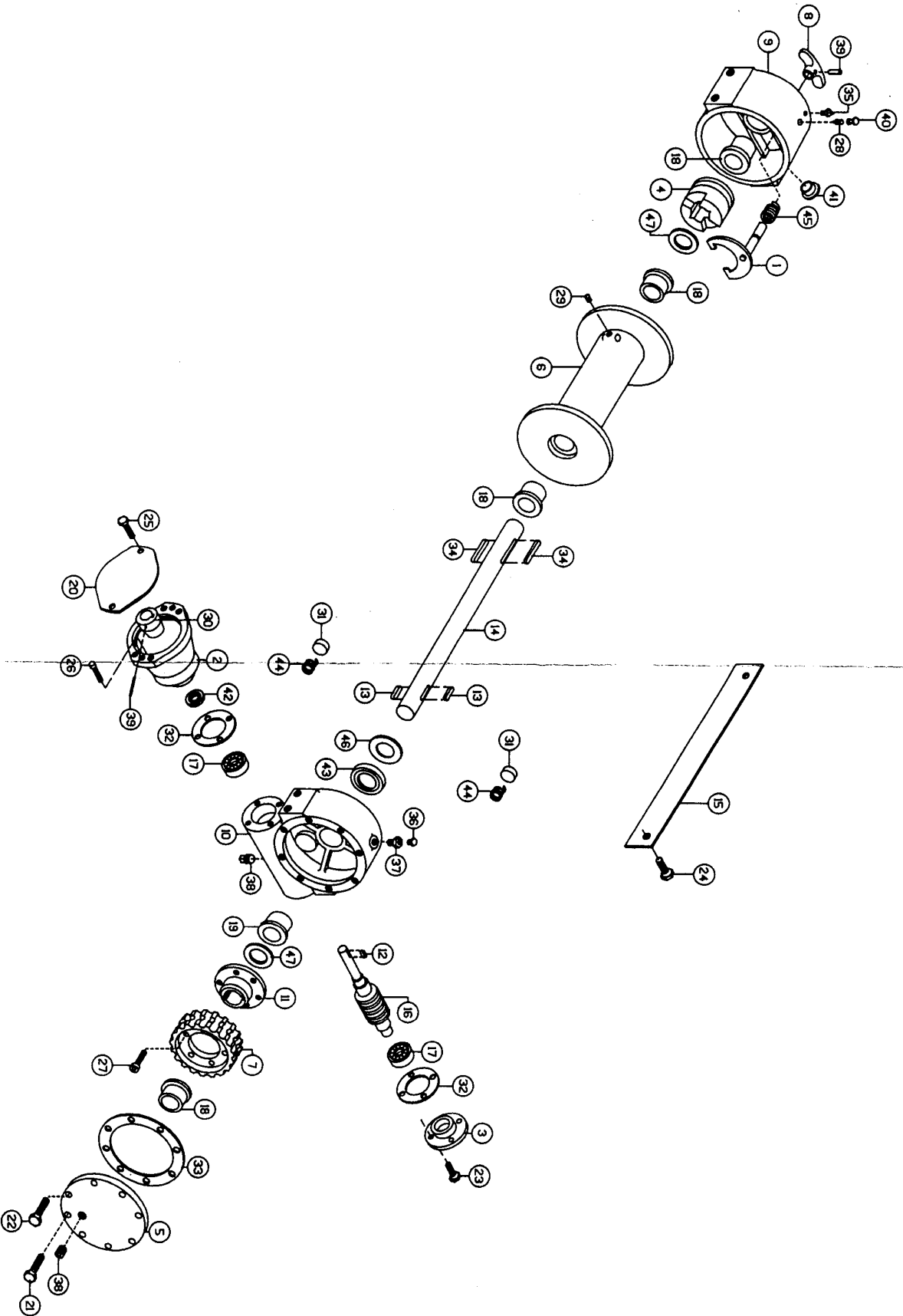

Rev. _____
Date _____

PARTS LIST — RAMSEY WINCH 121696

Ref. No.	Part No.	Description	Qty.
1	276028	Shifter Assembly	1
2	300057	Adapter	1
3	316083	Bearing Cap	1
4	324160	Jaw Clutch	1
5	328105	Cover	1
6	332007	Drum — "Y"	1
7*	334004	Gear R.H. 60:1	1
8	336010	Handle	1
9	338208	Housing — Clutch	1
10	338237	Housing — Gear	1
11*	340071	Hub — Gear	1
12	342027	Key	1
13	342075	Key	2
14	357464	Shaft — Drum — "Y"	1
15	364018	Shipping Strap	1
16	368007	Worm R.H. 60:1	1
17	402002	Bearing — Ball	2
18	412003	Bushing	4
19	412045	Bushing	1
20	413013	Cover — Adapter	1
21	414020	Capscrew ¼-20NCx¾ Lg. Hx. Hd. Gr.5 Nylok Hvy. Patch	1
22	414038	Capscrew ¼-20NCx¾ Lg. Hx. Hd. Gr.5	7
23	414045	Capscrew ¼-20NCx¾ Lg. Hx. Hd. Gr.5	4
24	414230	Capscrew ¾-16NCx½ Lg. Hx. Hd.	2
25	414521	Capscrew ½-13NCx1 Lg. Hx. Hd.	2
26	414842	Capscrew ¼-20NCx1¾ Lg. Soc. Hd. Lok-Wel	4
27*	414889	Capscrew 5/16-18NCx¾ Lg. Soc. Hd. (Torx Hd. Sems Unit)	6
28	416030	Setscrew ¼-20NCx¾ Soc. Hd. Less	1
29	416059	Setscrew ¾-16NCx½ Soc. Hd. Less	1
30	431008	Coupling	1
31	438014	Disc — Brake	2
32	442184	Gasket	2
33	442188	Gasket	1
34	450006	Key — Barth	2
35	456001	Fitting — Lube	1
36	456008	Fitting — Relief	1
37	468002	Reducer	1
38	468011	Pipe Plug	2
39	470033	Spirol Pin	2
40	472012	Plug — Rubber	1
41	472013	Plastic Plug	1

Rev. _____

Date _____

42	486009	Oil Seal	1
43	486017	Oil Seal	1
44	494002	Spring	2
45	494053	Spring	1
46	518014	Thrust Washer	1
47	518015	Thrust Washer	2

NOTE — Items marked with an asterisk (*) cannot be purchased as individual parts. These parts are factory set and sold as an assembly only. Gear/hub assembly part number is 250501 R.H. 60:1.

PARTS LIST — WHEEL LIFT LIFT CYLINDER

Ref. No.	Part No.	Description	Qty.
1	B4-763-000033	Cylinder Rod	1
2	A7-754-000002	Retaining Ring	2
3	A7-796-000008*	Rod Wiper Seal	1
4	A7-754-000004*	Wear Ring	1
5	B4-553-000002	Head	1
6	A7-796-000007*	Seal	1
7	7-755-334609*	Back-Up Ring	1
8	7-755-334000*	"O" Ring	1
9	7-755-214000*	"O" Ring	1
10	B4-698-000002	Piston	1
11	7-440-030000	Grease Fitting	1
12	C3-071-000013	Barrel Weldment	1
13	7-660-261630	Hex Locknut	1
14	A7-754-000003*	Wear Ring	1
15	A7-796-000006*	Piston Seal	1

* — Available only in Service Kit No. 9-577-250008

WHEEL LIFT LIFT CYLINDER

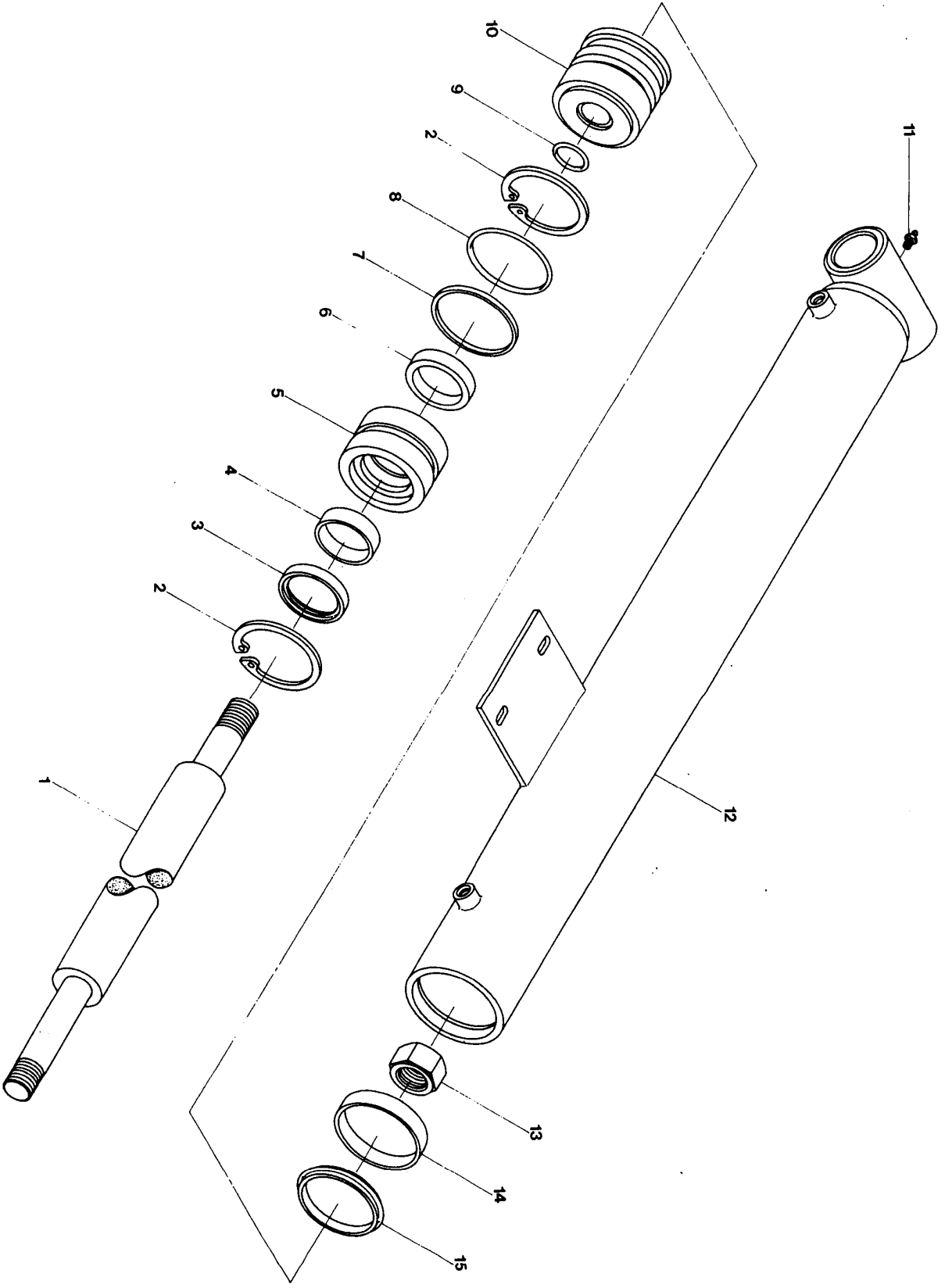

WHEEL LIFT EXTEND CYLINDER

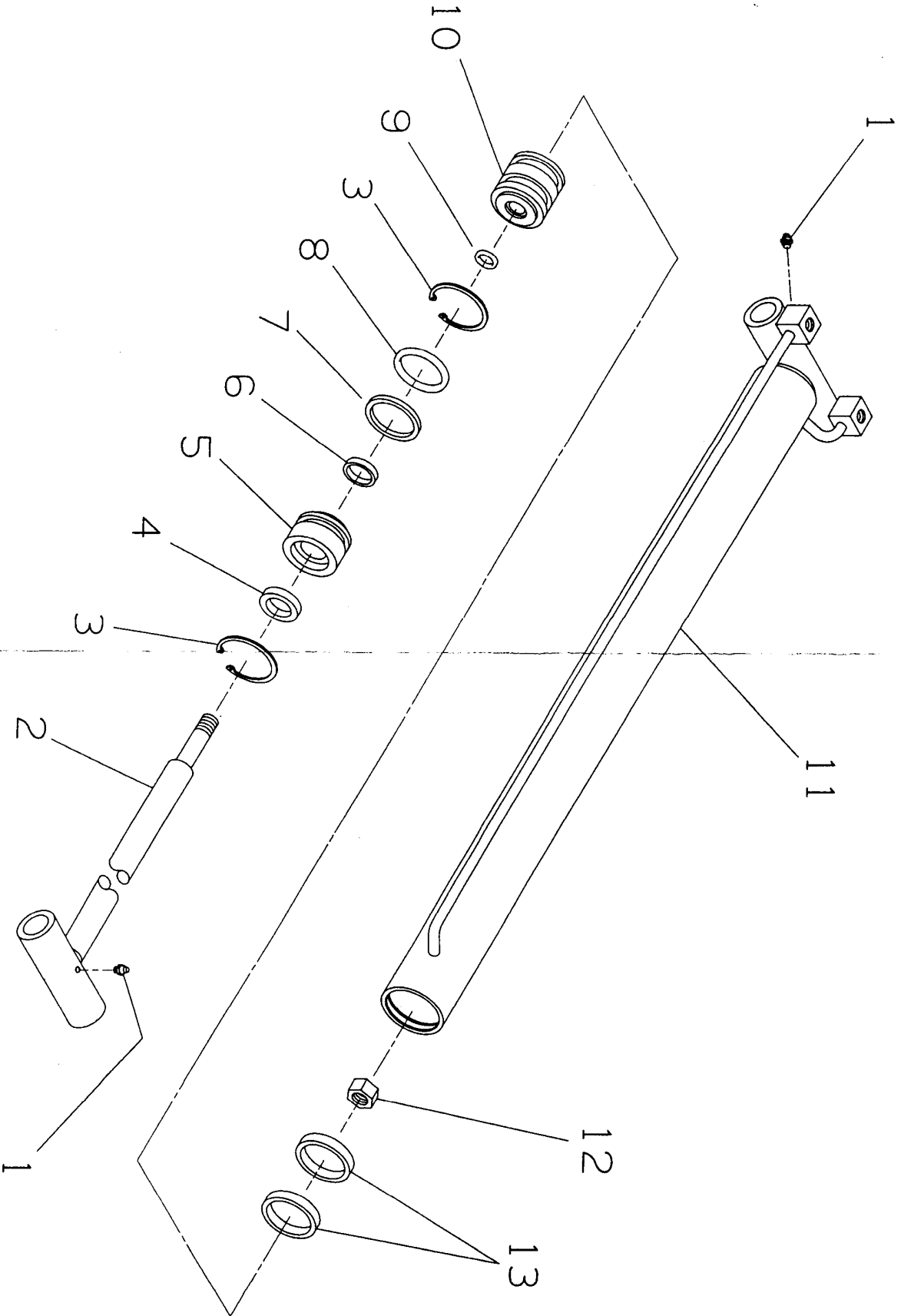

PARTS LIST — WHEEL LIFT EXTEND CYLINDER

Ref. No.	Part No.	Description	Qty.
1	7-440-030000	Grease Fitting	2
2	C3-763-000014	Rod Weldment	1
3	A4-754-000001	Retaining Ring	2
4	A7-796-000005*	Rod Wiper Seal	1
5	B4-553-000001	Head	1
6	A7-796-000004*	Rod Seal	1
7	7-755-327609*	Back-up Ring	1
8	7-755-327000*	"O" Ring	1
9	7-755-208000*	"O" Ring	1
10	B4-698-000001	Piston	1
11	D3-071-000016	Barrel Weldment	1
12	7-660-201631	Lock Nut	1
13	A7-796-000007*	Seal	2

* — Available only in Service Kit No. 9-577-250009

PARTS LIST — WHEEL LIFT TILT CYLINDER

Ref. No.	Part No.	Description	Qty.
1	B3-763-000015	Rod Weldment	1
2	A7-754-000013	Retaining Ring	2
3	A7-796-000011*	Rod Wiper Seal	1
4	A7-754-000012*	Wear Ring	1
5	B4-553-000004	Head	1
6	A7-796-000010*	Rod Seal	1
7	7-755-342609*	Back-Up Ring	1
8	7-755-342000*	"O" Ring	1
9	7-755-222000*	"O" Ring	1
10	C3-071-000017	Barrel Weldment	1
11	7-660-341631	Lock Nut	1
12	A7-754-000011*	Wear Ring	1
13	A7-796-000009*	Piston "T" Seal	1
14	B4-698-000003	Piston	1
15	7-440-030000	Grease Fitting	1

* — Available only in Service Kit No. 9-577-250012

WHEEL LIFT TILT CYLINDER

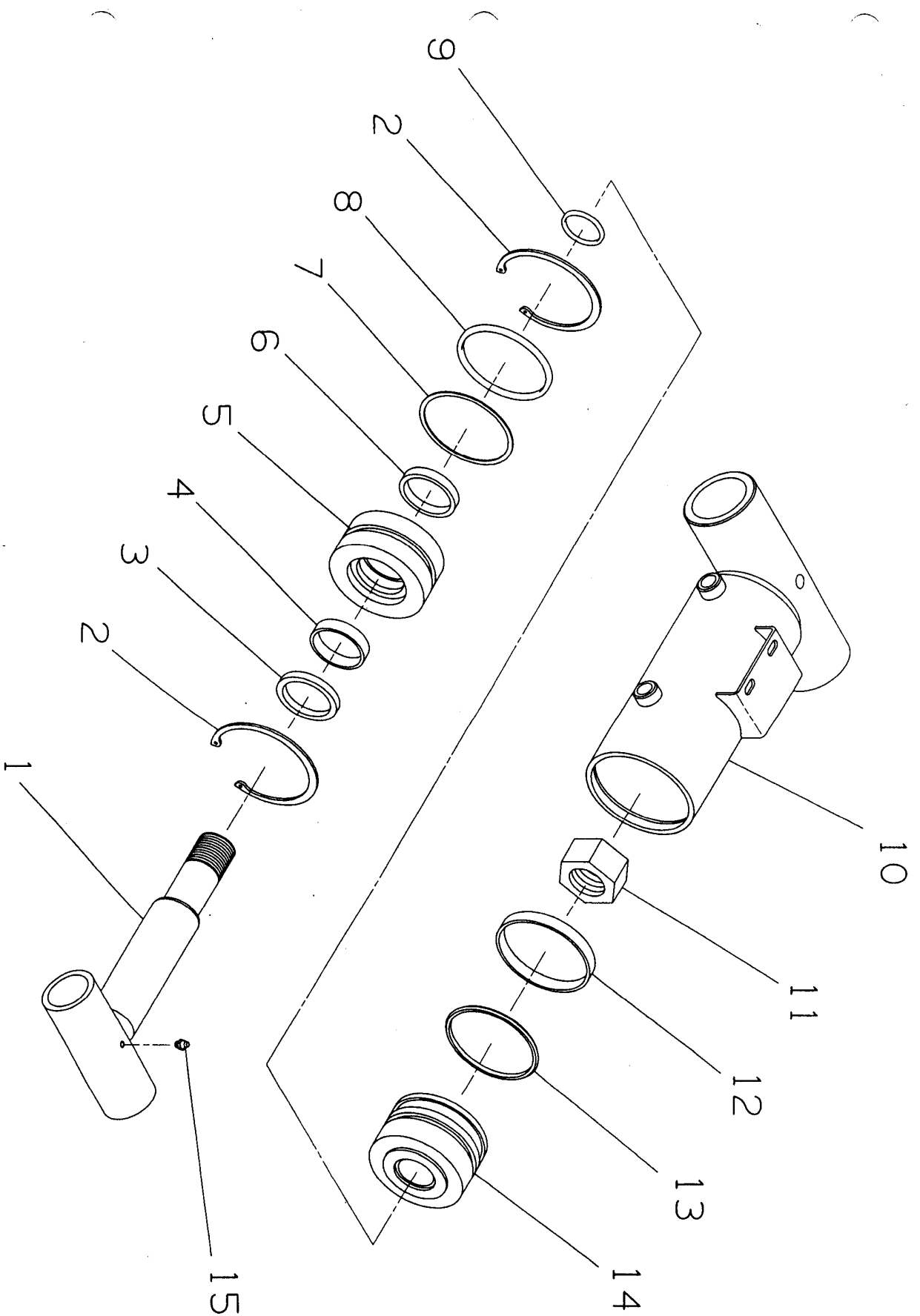

PARTS LIST — WRECKER BOOM EXTENSION CYLINDER

Ref. No.	Part No.	Description	Qty.
1	C3-763-000009	Rod Weldment	1
2	7-660-261630	Hex Lock Nut	1
3	A7-754-000003*	Wear Ring	1
4	A7-796-000006*	"T" Piston Seal	1
5	B4-698-000002	Piston	1
6	7-755-214000*	"O" Ring	1
7	A7-754-000002	Retaining Ring	2
8	A7-796-000007*	Seal	1
9	A7-754-000004*	Wear Ring	1
10	7-755-334000*	"O" Ring	1
11	7-755-334609*	Back-Up Ring	1
12	B4-553-000002	Head	1
13	A7-796-000008*	Rod Wiper Seal	1
14	D3-071-000007	Barrel Weldment	1

* — Available only in Service Kit No. 9-577-250008

WRECKER BOOM EXTENSION CYLINDER

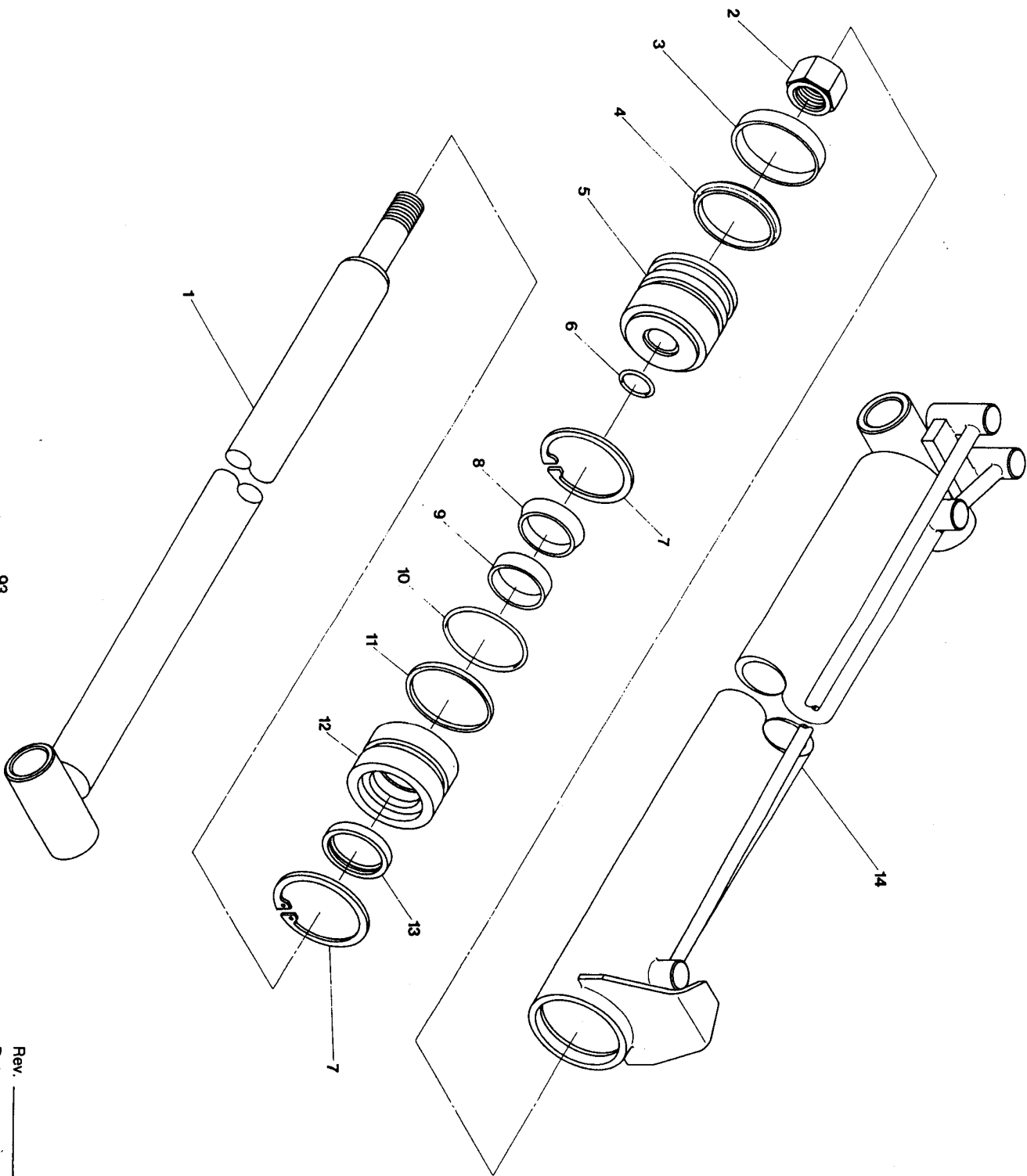

L.H. WRECKL. BOOM LIFT CYLINDER

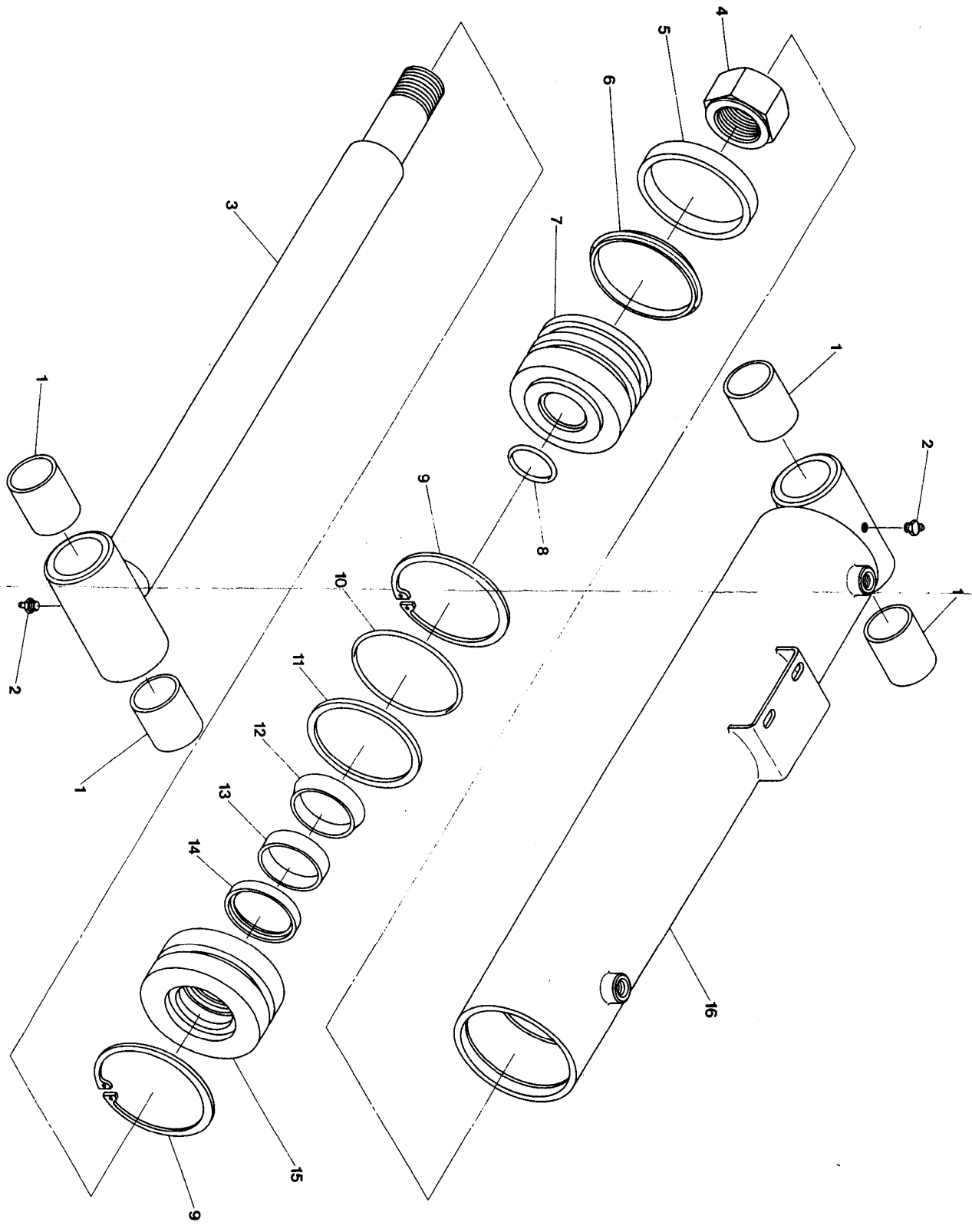

PARTS LIST — L.H. WRECKER BOOM LIFT CYLINDER

Ref. No.	Part No.	Description	Qty.
1	A7-209-000003	Bronze Bushing	4
2	7-440-030000	Grease Fitting	2
3	B3-763-000010	Rod Weldment	1
4	7-660-341631	Lock Nut	1
5	A7-754-000011*	Wear Ring	1
6	A7-796-000009*	Piston Seal "T"	1
7	B4-698-000003	Piston	1
8	7-755-222000*	"O" Ring	1
9	A7-754-000013	Retaining Ring	2
10	7-755-342000*	"O" Ring	1
11	7-755-342609*	Back-Up Ring	1
12	A7-796-000010*	Rod Seal	1
13	A7-754-000012*	Wear Ring	1
14	A7-796-000011*	Rod Wiper Seal	1
15	B4-553-000004	Head	1
16	D3-071-000011	Lift Barrel Weldment L.H.	1

* — Available only in Service Kit No. 9-577-250012

PARTS LIST — R.H. WRECKER BOOM LIFT CYLINDER

Ref. No.	Part No.	Description	Qty.
1	A7-209-000003	Bronze Bushing	4
2	7-440-030000	Grease Fitting	2
3	B3-763-000010	Rod Weldment	1
4	7-660-341631	Lock Nut	1
5	A7-754-000011*	Wear Ring	1
6	A7-796-000009*	Piston Seal "T"	1
7	B4-698-000003	Piston	1
8	7-755-222000*	"O" Ring	1
9	A7-754-000013	Retaining Ring	2
10	7-755-342000*	"O" Ring	1
11	7-755-342609*	Back-Up Ring	1
12	A7-796-000010*	Rod Seal	1
13	A7-754-000012*	Wear Ring	1
14	A7-796-000011*	Rod Wiper Seal	1
15	B4-553-000004	Head	1
16	D3-071-000012	Lift Barrel Weldment R.H.	1

* — Available only in Service Kit No. 9-577-250012

R.H. WRECKER BOOM LIFT CYLINDER

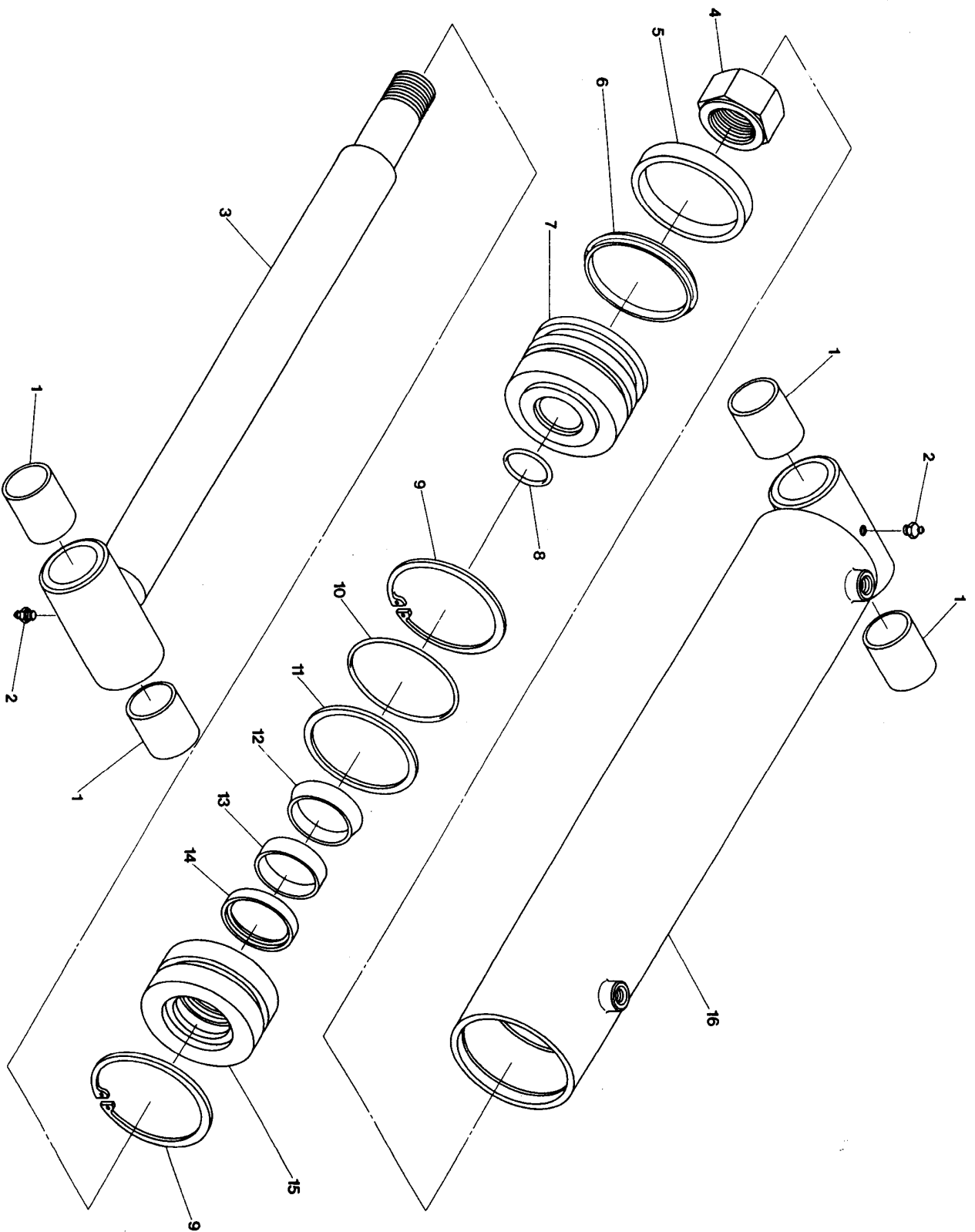

HYDRAULIC COMPONENTS (Reservoir & Valves)

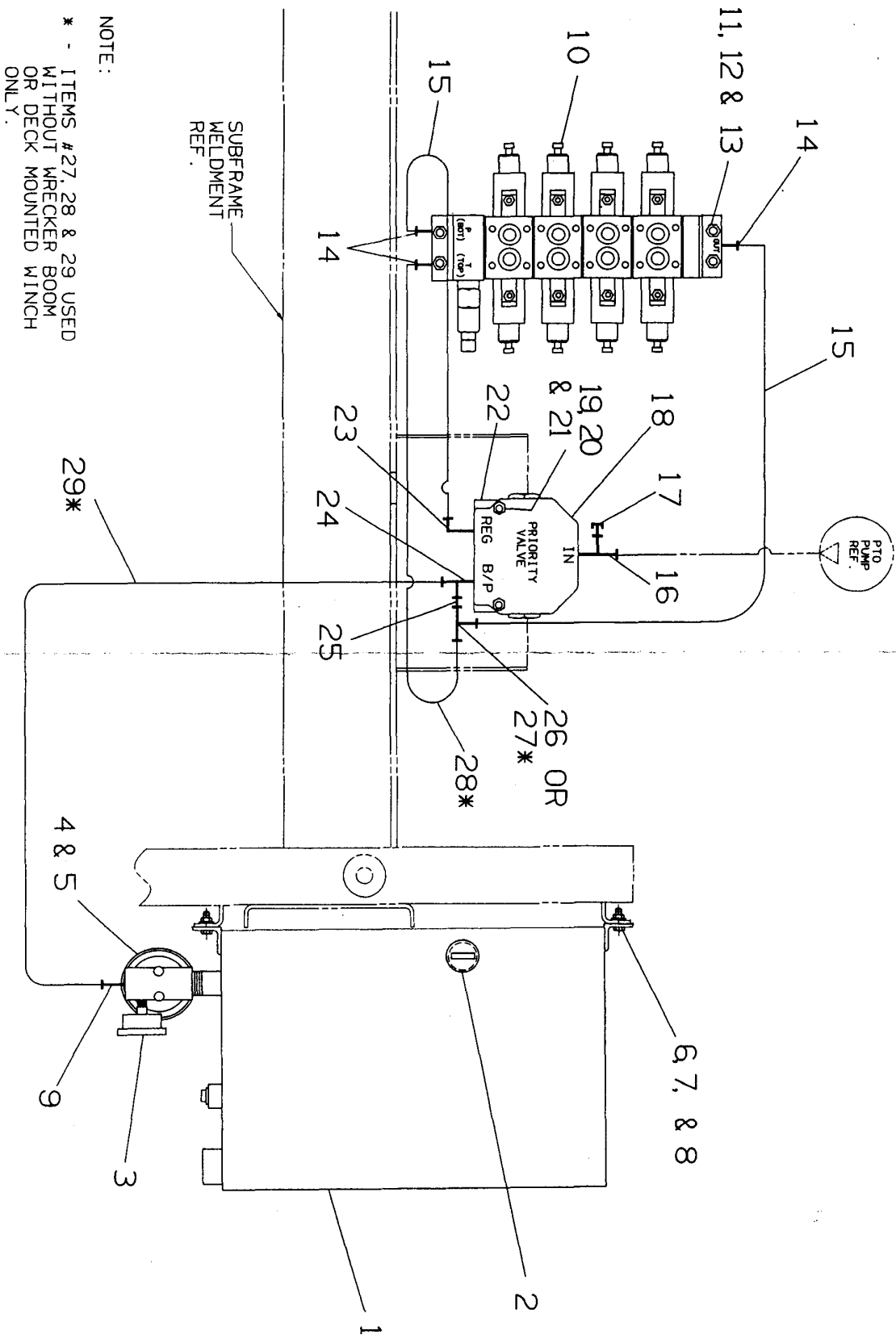

SUBFRAME
WELDMENT
REF.

NOTE:
* - ITEMS #27, 28 & 29 USED
WITHOUT WRECKER BOOM
OR DECK MOUNTED WINCH
ONLY.

**PARTS LIST — HYDRAULIC COMPONENTS
(Reservoir & Valves)**

Ref. No.	Part No.	Description	Qty.
1	C3-750-000001	Oil Reservoir	1
2	B7-470-000001	Dipstick	1
3	A7-470-000002	Gauge	1
4	A7-430-000002	Filter Head	1
5	A7-431-000001	Filter Element	1
6	7-111-150850	Hex Cap Screw	4
7	7-950-150161	Flatwasher	4
8	7-660-152600	Hex Locknut	4
9	7-445-121619	Straight Adapter	1
10	A7-935-000019	Directional Valve	1
11	7-111-140850	Hex Cap Screw	4
12	7-950-140161	Flatwasher	4
13	7-660-142600	Hex Locknut	4
14	7-445-060643	Straight Adapter	3
15	4-567-222022	Hose Assembly	2
16	7-445-080848	Run Tee	1
17	7-445-080818	Nut Cap	1
18	A7-935-000020	Priority Valve	1
19	7-111-142850	Hex Cap Screw	2
20	7-950-140161	Flatwasher	2
21	7-660-142600	Hex Locknut	2
22	A4-263-000011	Channel	1
23	7-445-060645	90° Elbow	1
24	7-445-121248	Run Tee	1
25	7-443-000011	Reducer	1
26	7-445-060672	90° Elbow	1
27*	7-443-000030	Run Tee	1
28*	4-567-222022	Hose Assembly	1
29*	4-567-460048	Hose Assembly	1

* — Items #27, 28 & 29 used without winch or wrecker boom only.

Rev. _____

Date _____

PARTS LIST — HYDRAULIC COMPONENTS (Wheel Lift)

Ref. No.	Part No.	Description	Qty.
1	C3-320-000014	Lift Cylinder	1
2	C3-320-000017	Extension Cylinder	1
3	D3-320-000016	Tilt Cylinder	1
4	7-445-040643	Straight Adapter	7
5	7-445-040472	90° Swivel Elbow	5
6	A7-443-000026	Swivel Tee Run	1
7	A7-443-000053	Restrictor Adapter	2
8	A7-443-000052	Swivel Tee	1
9	7-445-040645	90° Elbow	11
10	7-445-040446	45° Elbow	2
11	7-445-040445	90° Elbow	1
12	7-445-040443	Straight Adapter	1
13	C7-912-000014	Tube Assembly	1
14	B7-912-000013	Tube Assembly	1
15	B7-912-000005	Tube Assembly	1
16	B7-912-000010	Tube Assembly	1
17	4-567-210109	Hose Assembly	4
18	4-567-410035	Hose Assembly	1
19	4-567-410040	Hose Assembly	1
20	4-567-210017	Hose Assembly	1
21	4-567-210014	Hose Assembly	1
22	B7-935-000011	Combination Valve	1
23	A7-935-000001	Counterbalance Valve	1
24	B7-935-000016	Check Valve	1
25	7-111-151650	Hex Cap Screw	2
26	7-950-150161	Flat Washer	4
27	7-660-152600	Hex Lock Nut	4
28	7-115-152650	Hex Cap Screw	2
29	A7-819-000008	Hose Sleeve	1
30	A7-274-000003	Loop Clamp	3
31	7-660-142600	Hex Lock Nut	3

Rev. _____

Date _____

HYDRAULIC COMPONENTS (Wheel Lift)

SOLENOID DIRECTIONAL CONTROL VALVE REF.

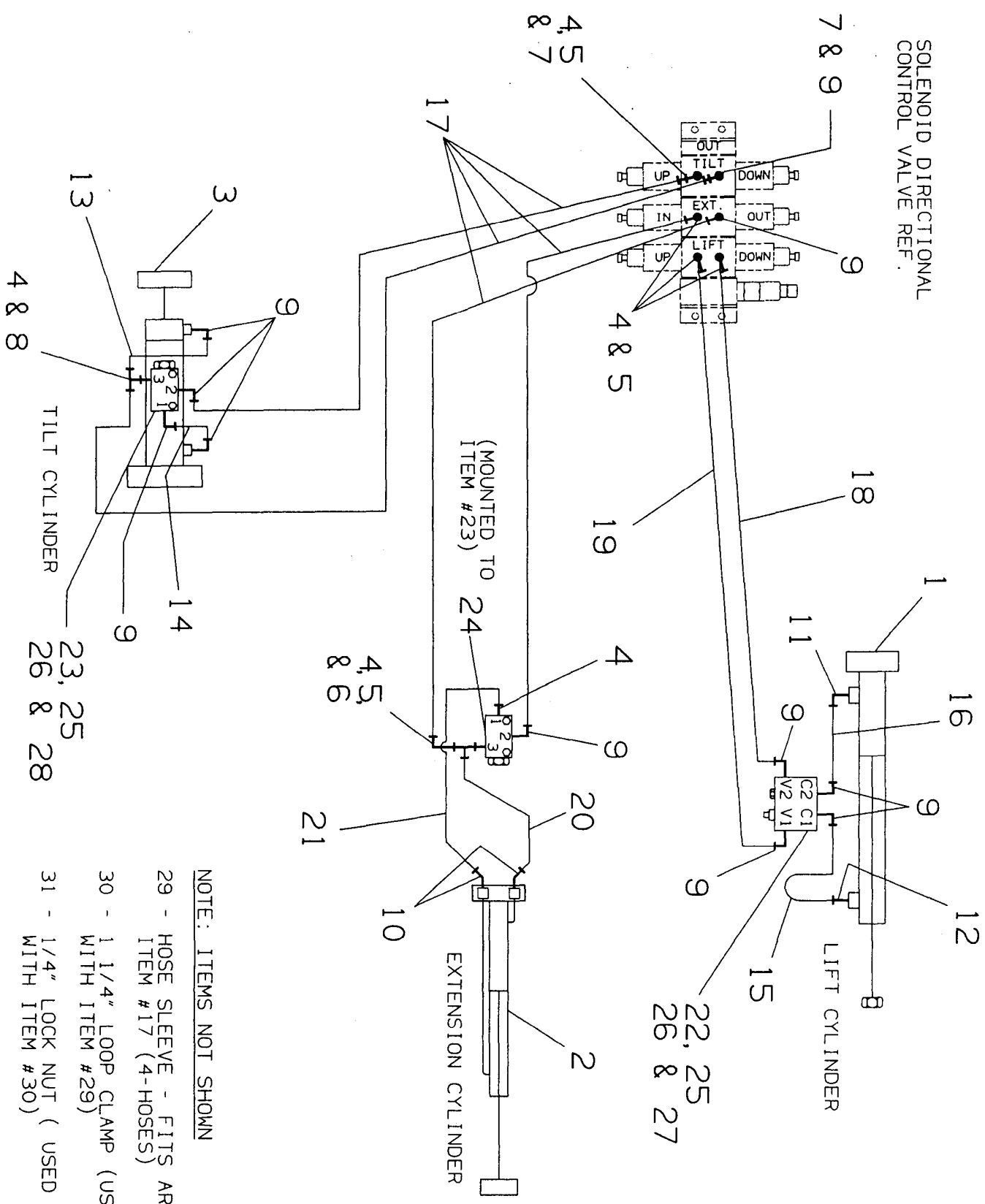

NOTE: ITEMS NOT SHOWN

- 29 - HOSE SLEEVE - FITS AROUND ITEM #17 (4-HOSES)
- 30 - 1 1/4" LOOP CLAMP (USED WITH ITEM #29)
- 31 - 1/4" LOCK NUT (USED WITH ITEM #30)

HYDRAULIC COMPONENTS (PTO or Clutch Pump)

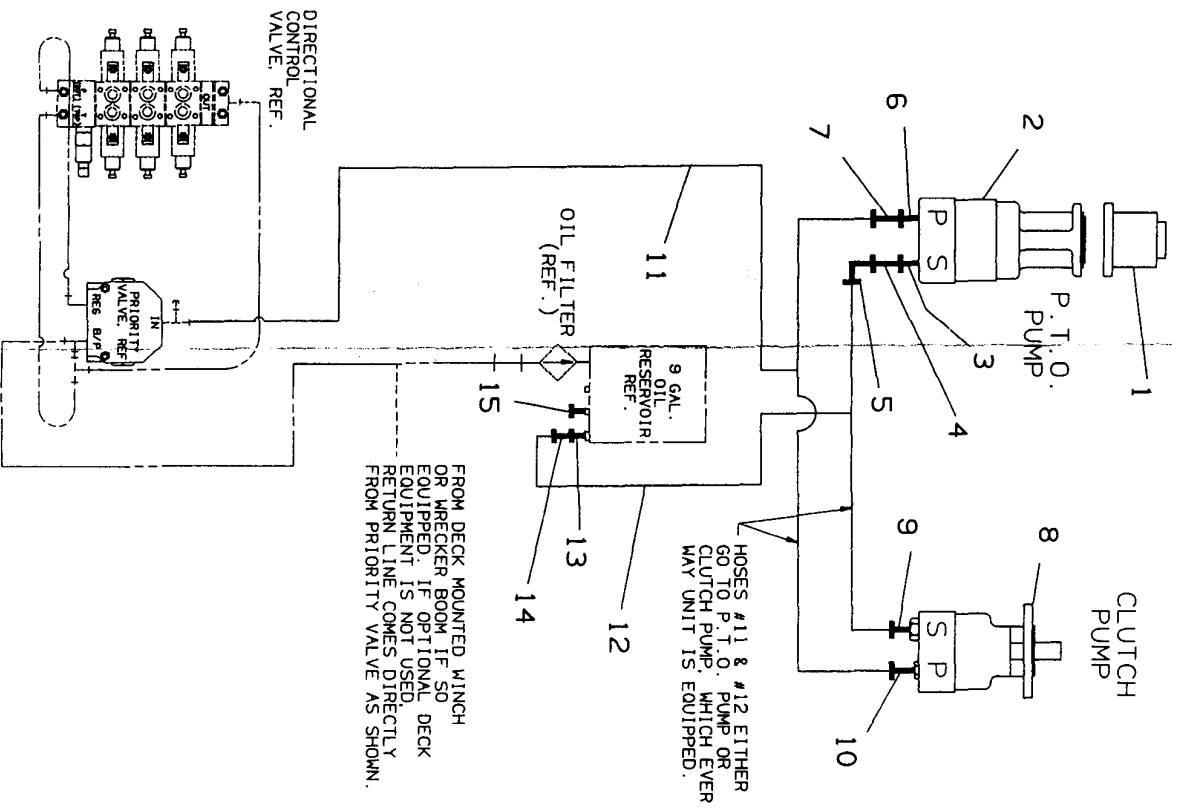

CIRCUIT FOR P. T. O. PUMP OR CLUTCH PUMP

**PARTS LIST — HYDRAULIC COMPONENTS
P.T.O. PUMP CIRCUIT**

Ref. No.	Part No.	Description	Qty.
1		P.T.O.	1
2		P.T.O. Pump	1
3		Pipe Nipple	1
4		Hydraulic Fitting	1
5		Hydraulic Fitting	1
6		Reducer	1
7		Hydraulic Fitting	1
11		Hose Assembly	1
12		Hose Assembly	1
13		Hydraulic Fitting	1
14		Hydraulic Fitting	1
15		Hydraulic Fitting	1

PARTS LIST — CLUTCH PUMP CIRCUIT

Ref. No.	Part No.	Description	Qty.
8		Clutch Pump	1
9		45° Elbow	1
10		Straight Adapter	1
11		Hose Assembly	1
12		Hose Assembly	1
13		Hydraulic Fitting	1
14		Hydraulic Fitting	1
15		Hydraulic Fitting	1

NOTE — Contact factory for all replacement parts.

PARTS LIST — HYDRAULIC COMPONENTS — WINCH

Ref. No.	Part No.	Description	Qty.
1	A7-970-000002	Winch (Ramsey)	1
2	A7-626-000002	Orbit Motor (Char-Lynn)	1
3	7-111-181050	Hex Cap Screw	2
4	7-950-180400	Lockwasher	2
5	7-445-081045	90° Elbow	2
6	4-567-430030	Hose Assembly	2
7	A7-935-000002	Directional Valve	1
8	7-111-162050	Hex Cap Screw	3
9	7-660-162601	Hex Locknut	3
10	7-950-160161	Flatwasher	3
11	7-445-081245	90° Elbow	1
12	7-445-121245	90° Elbow	1
13	4-567-460038	Hose Assembly	1
14	7-445-060672	90° Elbow	1
15	A7-443-000012	Run Tee	1
16	A7-443-000011	Swivel Reducer	1
17	4-567-422044	Hose Assembly	1
18	A7-443-000049	Swivel Reducer	1
19	4-567-630036	Hose Assembly	1
20	7-445-080820	90° Elbow	2

HYDRAULIC COMPONENT (Single Winch Wrecker Boom)

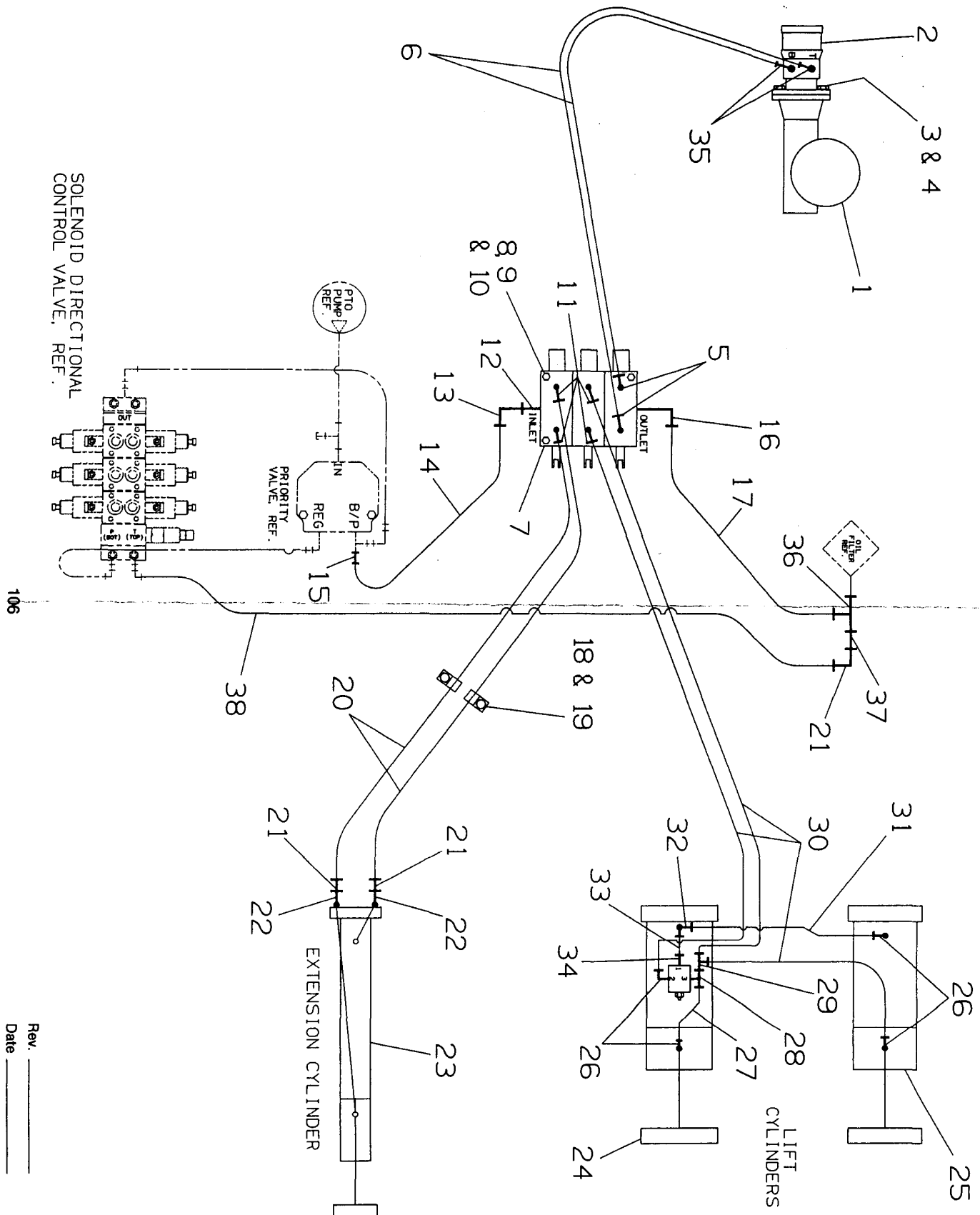

SOLENOID DIRECTIONAL CONTROL VALVE, REF.

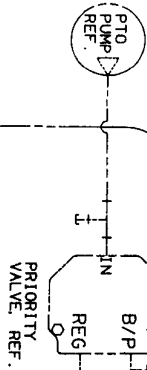

106

Rev. _____
Date _____

**PARTS LIST — HYDRAULIC COMPONENTS
(Single Winch Wrecker Boom)**

Ref. No.	Part No.	Description	Qty.
1	A7-970-000005	Winch (Ramsey)	1
2	A7-626-000002	Orbit Motor (Char-Lynn)	1
3	7-111-181050	Hex Cap Screw	2
4	7-950-180400	Lockwasher	2
5	7-445-081043	Straight Adapter	2
6	4-567-432027	Hose Assembly	2
7	A7-935-000009	Directional Valve	1
8	7-111-162250	Hex Cap Screw	3
9	7-950-160161	Flatwasher	3
10	7-660-162601	Hex Locknut	3
11	7-445-061043	Straight Adapter	4
12	A7-443-000003	Reducer	1
13	A7-443-000028	90° Elbow	1
14	4-567-630030	Hose Assembly	1
15	A7-443-000049	Swivel Reducer	1
16	7-445-121245	90° Elbow	1
17	4-567-460027	Hose Assembly	1
18	A7-274-000010	Clamp	2
19	7-660-142600	Locknut	2
20	4-567-222034	Hose Assembly	2
21	7-445-060672	90° Elbow	3
22	7-445-060643	Straight Adapter	2
23	D3-320-000007	Extend Cylinder	1
24	D3-320-000011	L.H. Lift Cylinder	1
25	D3-320-000012	R.H. Lift Cylinder	1
26	7-445-060645	90° Elbow	4
27	A4-570-000008	Hose Assembly	1
28	7-445-060647	Branch Tee	1
29	A7-443-000030	Run Tee	1
30	4-567-222022	Hose Assembly	3
31	B7-912-000002	Tube Assembly	1
32	7-445-060648	Run Tee	1
33	B7-912-000001	Tube Assembly	1
34	7-445-060646	45° Elbow	1
35	7-445-080819	Straight Adapter	2
36	A7-443-000012	Run Tee	1
37	A7-443-000011	Swivel Reducer	1
38	4-567-422044	Hose Assembly	1

**PARTS LIST — HYDRAULIC COMPONENTS
(Dual Winch Wrecker Boom)**

Ref. No.	Part No.	Description	Qty.
1	A7-970-000005	L.H. Winch (Ramsey)	1
2	A7-970-000004	R.H. Winch (Ramsey)	1
3	A7-626-000002	Orbit Motor (Char-Lynn)	2
4	7-111-181050	Hex Cap Screw	4
5	7-950-180400	Lockwasher	4
6	7-445-080819	Straight Adapter	4
7	A7-443-000023	90° Elbow	4
8	4-567-432036	Hose Assembly	4
9	7-445-081043	Straight Adapter	4
10	A7-935-000008	Directional Valve	1
11	7-111-162250	Hex Cap Screw	3
12	7-950-160161	Flatwasher	3
13	7-660-162601	Hex Locknut	3
14	7-445-061043	Straight Adapter	4
15	7-445-081245	90° Elbow	1
16	4-567-630030	Hose Assembly	1
17	A7-443-000049	Swivel Reducer	1
18	7-445-121245	90° Elbow	1
19	4-567-460027	Hose Assembly	1
20	A7-274-000010	Clamp	2
21	7-660-142600	Locknut	2
22	4-567-222034	Hose Assembly	2
23	7-445-060672	90° Elbow	3
24	7-445-060643	Straight Adapter	2
25	D3-320-000007	Extend Cylinder	1
26	D3-320-000011	L.H. Lift Cylinder	1
27	D3-320-000012	R.H. Lift Cylinder	1
28	7-445-060645	90° Elbow	4
29	A4-570-000008	Hose Assembly	1
30	7-445-060647	Branch Tee	1
31	A7-443-000030	Run Tee	1
32	4-567-222022	Hose Assembly	3
33	B7-912-000002	Tube Assembly	1
34	7-445-060648	Run Tee	1
35	B7-912-000001	Tube Assembly	1
36	7-445-060646	45° Elbow	1
37	A7-443-000012	Run Tee	1
38	A7-443-000011	Swivel Reducer	1
39	4-567-422044	Hose Assembly	1

HYDRAULIC COMPONENTS (Dual Winch Wrecker Boom)

